



**ADH<sup>®</sup> NETCOM<sup>™</sup> AUTOMATIC AIR DEHYDRATOR  
MAIN CIRCUIT BOARD ASSEMBLY  
REPLACEMENT PROCEDURE**

**Replacement Kit Part Number 24084  
Document Part Number 24097**

## SAFETY INFORMATION AND WARNINGS

### Abnormal Odor or Smoke



In the event of smoke or a burning or abnormal odor, immediately interrupt power to the ADH NETCOM with the POWER switch at the rear of the unit, unplug the unit, or turn off the circuit breaker controlling the outlet. Note that only the AC model of the ADH NETCOM has an ON / OFF switch.

### Lethal Voltages Present



Lethal voltages are present inside the ADH NETCOM. Service should be performed by qualified personnel only. There are no user serviceable components inside the chassis.

### Pneumatics



Each of the air pumps inside the ADH NETCOM automatic air dehydrator is capable of generating as much as 24 psig (1,655mbar). Other attached dry air sources may be capable of generating even higher pressures. Proper safety practice requires treating all pneumatic components with care. Always vent the system to atmospheric pressure before servicing pneumatic components.

### Rack Mounting



Before and after rack mounting the ADH NETCOM, ensure that the rack is stable. Mounting of the ADH NETCOM into a rack should be such that a hazardous condition is not created due to uneven mechanical loading. Verify that adequate air flow and power source capacity is available to the unit. Ensure that the ADH NETCOM maximum operating temperature of 130°F (55°C) will not be compromised by other components in the rack. Ensure reliable earthing of the ADH NETCOM.

# ADH NETCOM MAIN CIRCUIT BOARD ASSEMBLY REPLACEMENT PROCEDURE

This procedure addresses the removal and replacement of the Main Circuit Board Assembly in an ADH NETCOM Automatic Air Dehydrator. The first section addresses the replacement of the Main Circuit Board Assembly in ADH NETCOM AC and DC units. The second section, starting on page 13, addresses replacement of the Main Circuit Board Assembly in an ADH NETCOM AC NEMA unit. It is recommended to read the entire procedure prior to beginning work.

## INVENTORY LIST

Identify the following items in this kit prior to beginning work.

## TOOLS REQUIRED

The following tools are needed to perform this procedure:

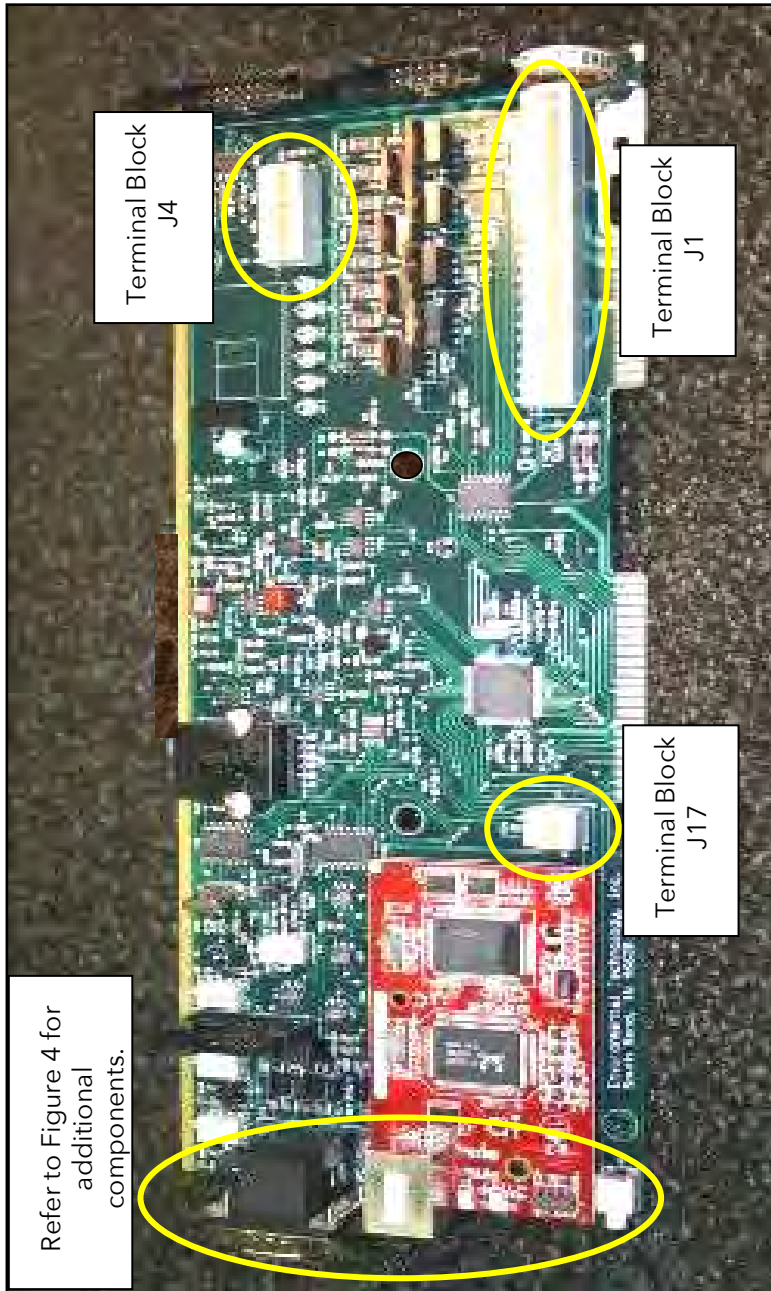
- Straight slot screwdriver
- Tubing wrench or vacuum tube pliers
- 1/4-inch nut driver
- Long Phillips screwdriver
- ESD wrist strap and mat
- 5/16 - inch nut driver

## INTRODUCTION

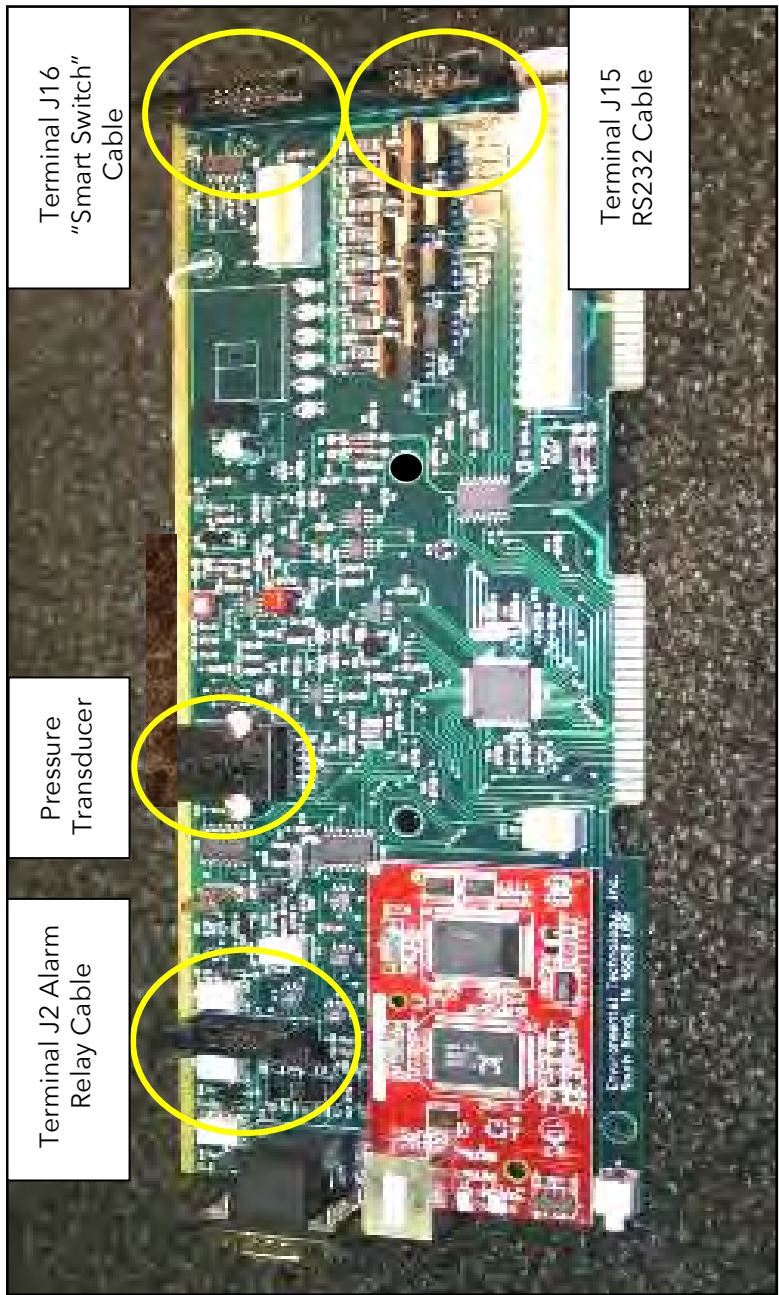
Because the Main Circuit Board Assembly is so important, as well as so difficult to see, given the way it's installed inside the chassis, it is useful to see the entire assembly with nothing in its way or connected to it. Refer to Figures 1a and 1b on the following page. Items J4, J17, and J1 are the terminal blocks to which all electrical power connectors inside the chassis are wired and from which all machine components derive their power.

Given the complexity of the terminal block wiring configuration, as well as the importance of making those connections correctly, several photographs in this manual will help in that effort. It might be useful to review the photographs even before disconnecting the leads from any of the three terminal blocks.

Item Number	Part Number	Item Quantity	Item Description
1	23253	1	Main Circuit Board Assembly
2	24097	1	Instruction Manual (this document)



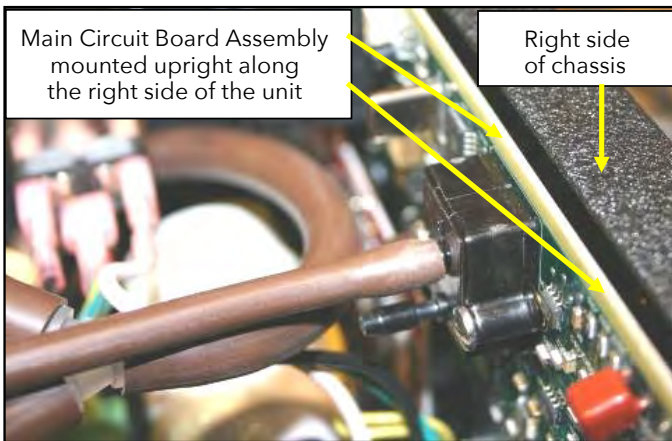
**Figure 1a. THE ADH NETCOM MAIN CIRCUIT BOARD ASSEMBLY.**



**Figure 1b. THE ADH NETCOM MAIN CIRCUIT BOARD ASSEMBLY.**

## MAIN CIRCUIT BOARD ASSEMBLY REMOVAL AND REPLACEMENT

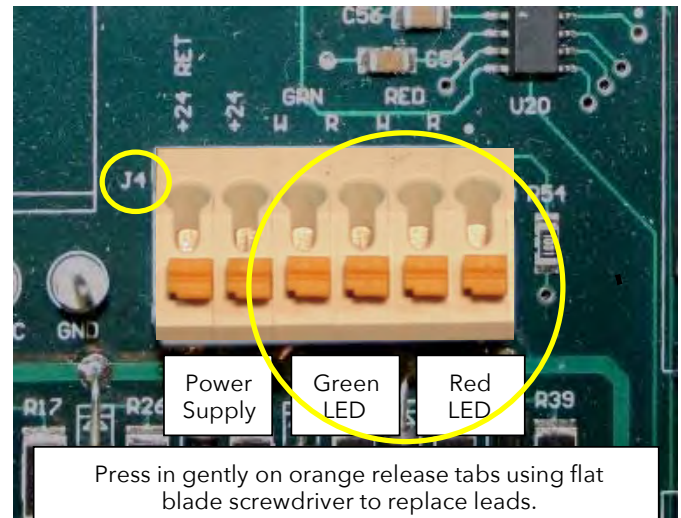
To replace the Main Circuit Board Assembly (23253) in either an ADH NETCOM Automatic Air Dehydrator with AC power or an ADH NETCOM with Redundant DC power, perform the steps below. Refer to Figure 2. To replace the Main Circuit Board Assembly (23253) in an ADH NETCOM AC NEMA unit, proceed to page 13.



**Figure 2. MAIN CIRCUIT BOARD ASSEMBLY INSTALLED.**

1. Shut off AC machine power by placing the power switch in the OFF (O) position, then unplugging the power cord. Shut off DC machine power by shutting off the external power supply. If possible, move the dehydrator to a work table.
2. An Electro-Static Discharge (ESD) wrist strap and mat are required to handle a PC board and perform this procedure safely. If you haven't already done so, put on an ESD wrist strap and work on an ESD mat.

3. Remove both top panels and the front panel. To remove the front panel, it is necessary to disconnect the two sets of electrical leads (4 total) coming from the front panel green and red LEDs, connected to the four terminals on the right side of circuit board terminal block J4. Refer to Figure 3. Press in on the orange release tabs under each lead, then carefully remove the four LED leads from circuit board terminal block J4. Retain the mounting hardware from all three panels. Because they are not interchangeable, keep the mounting hardware separate with each panel to facilitate re-installation.



**Figure 3. TERMINAL BLOCK J4.**

4. Once the front and top panels have been removed, disconnect the "Smart Switch" cable, if present, and the RS232 cable from the two receptacles on right side of the circuit board. The "Smart Switch" cable is the upper one; the RS232 cable is the lower one. Disconnect the Alarm Relay cable from the receptacle on the left side of the board. Refer back to Figure 1b. Gently fold back the release handles and the cable will disconnect.

- Both the RS422 A and B communications ports, as well as the Ethernet communications port, all on the back of the dehydrator, are actually part of the Main Circuit Board Assembly from inside the unit. For that reason, disconnect any cables which might be connected to any of these three ports. Refer to Figure 4. It is not necessary to remove either the 15-pin Alarm Relay cable or the 9-pin RS232 communications cable from the back of the unit.



Though visible from the back of the unit, these components are actually part of the Main Circuit Board Assembly.

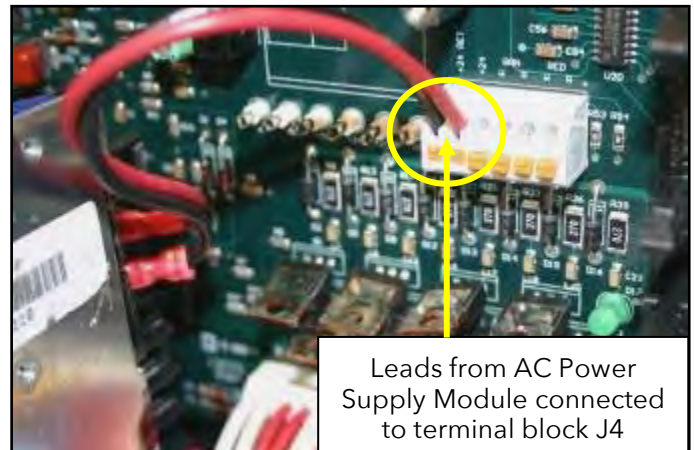
Remove and replace the board carefully to avoid damaging these or any other components.

Figure 4. MAIN CIRCUIT BOARD ASSEMBLY BACK PANEL COMPONENTS.

- For better access to the Main Circuit Board Assembly and the leads installed in terminal blocks J4, J17, and J1, it is recommended, on AC units, to remove the AC Power Supply Module, as well as the Compressor (pump) Assembly. On DC units, remove only the Compressor Assembly. Perform the steps found under each of those headings below.

## REMOVAL OF THE AC POWER SUPPLY MODULE

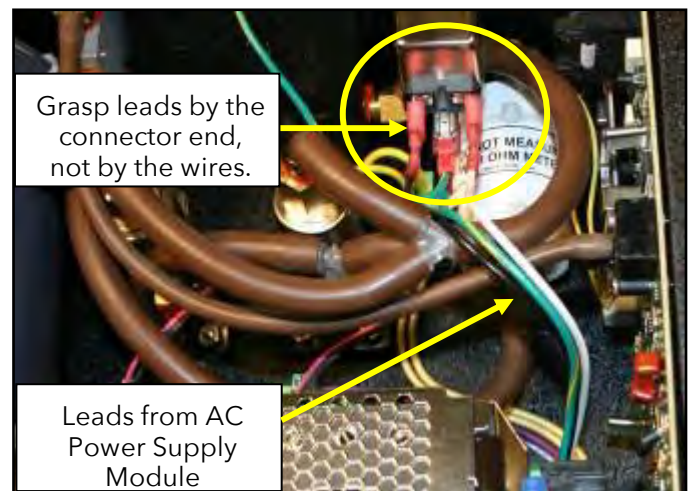
- Disconnect the red and black leads running from the AC power supply module to terminal block J4. Refer to Figure 5. Using a small screwdriver, press in on the orange release tab under the lead then gently remove the lead. Repeat for the other lead.



Leads from AC Power Supply Module connected to terminal block J4

Figure 5. TERMINAL BLOCK J4.

- Using a needle nose pliers, carefully disconnect the three leads (white, black, and green/yellow) running from the AC power supply module to the back of the power filter module. Refer to Figure 6.

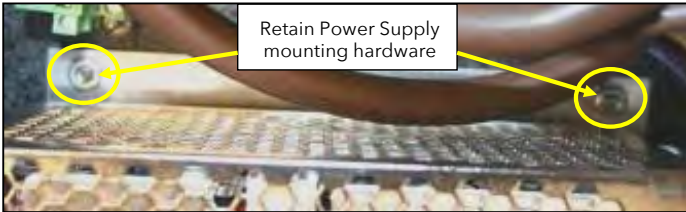


Grasp leads by the connector end, not by the wires.

Leads from AC Power Supply Module

Figure 6. POWER FILTER MODULE TERMINALS.

- Using the 5/16" nut driver, loosen and remove the two nuts and lock washers securing the existing AC power supply module to the chassis. Refer to Figure 7. Retain the mounting hardware.

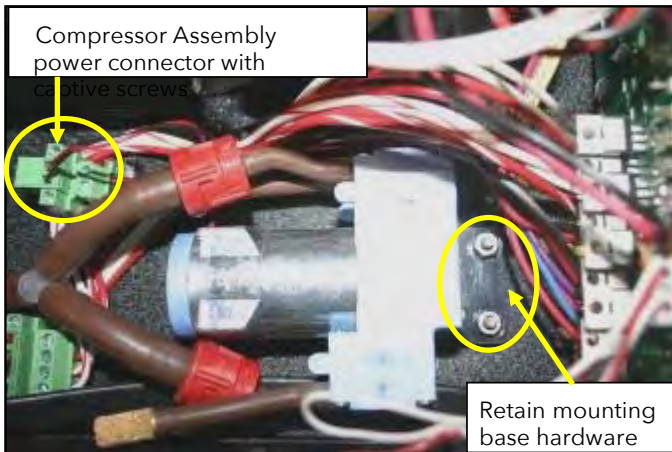


**Figure 7. AC POWER SUPPLY MODULE.**

- Once all five AC power supply module leads have been disconnected and the mounting hardware removed, take the existing AC power supply module out of the dehydrator.

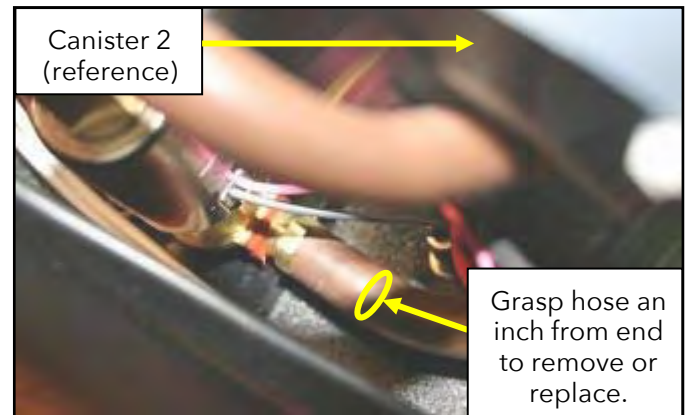
#### REMOVAL OF THE COMPRESSOR ASSEMBLY

- Loosen the captive screw at each end of the Compressor Assembly power connector. Refer to Figure 8. Captive screws cannot be removed. Once the two screws are loose, disconnect the green power connector.



**Figure 8. COMPRESSOR ASSEMBLY.**

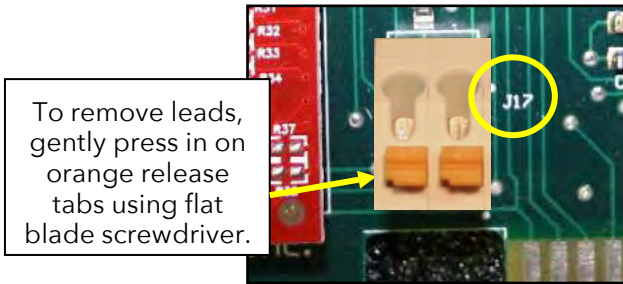
- Using the 5/16" nut driver, loosen and remove the nuts and lock washers securing the existing compressor mounting bracket to the chassis. Retain the mounting hardware for re-use.
- Using a tubing wrench or vacuum tube pliers, grasp the compressor air hose (in front of canister 2) about an inch from the end (refer to Figure 9), then pull gently to disconnect hose from fitting. With the mounting base and air hose disconnected, remove the compressor from the chassis.



**Figure 9. COMPRESSOR ASSEMBLY AIR HOSE.**

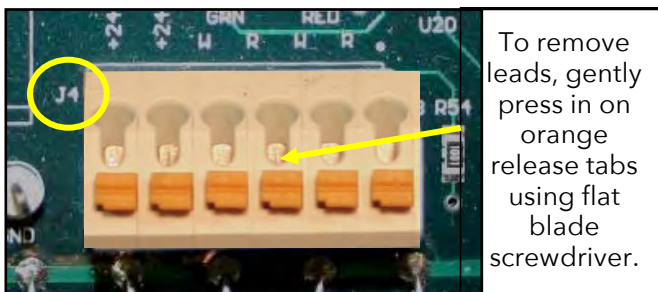
- With the AC Power Supply Module and Compressor Assembly disconnected and out of the way, we can now begin disconnecting the internal power connector leads from the circuit board terminal blocks.
- From circuit board terminal block J17, carefully remove the two yellow leads coming from the humidity sensor. Refer to Figure 10. Use a flat blade screwdriver to gently press in on either orange release tab, then gently remove the lead from the terminal. Repeat for the second lead.





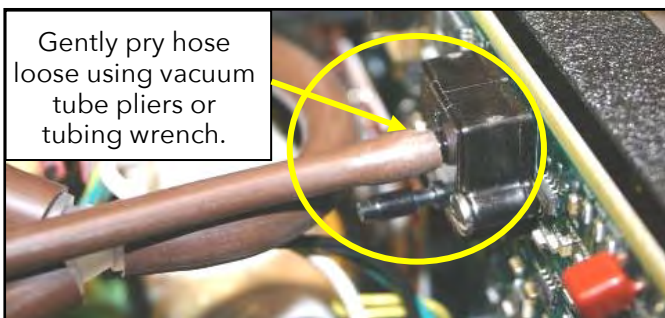
**Figure 10. TERMINAL BLOCK J17.**

16. By now, all six leads should be disconnected from terminal block J4. Refer to Figure 11. Make sure there are no more leads in J4.



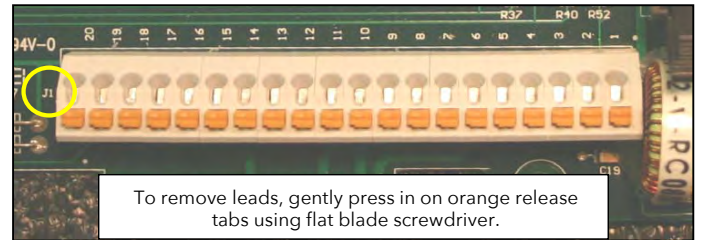
**Figure 11. TERMINAL BLOCK J4.**

17. Using tubing wrench or vacuum tube pliers, gently disconnect the outlet manifold air hose from the upper port of the pressure transducer. Refer to Figure 12. Once disconnected, move the hose out of the way.



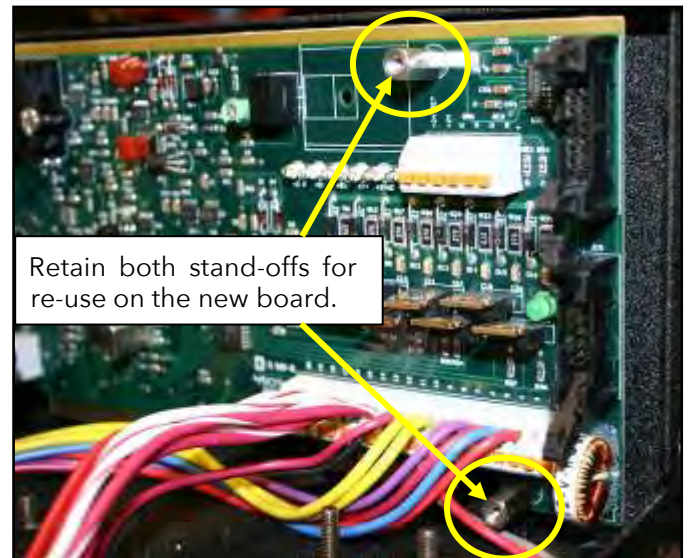
**Figure 12. PRESSURE TRANSDUCER.**

18. From circuit board terminal block J1, carefully remove all leads connected to it. Refer to Figure 13. Disconnect all leads from terminal block.



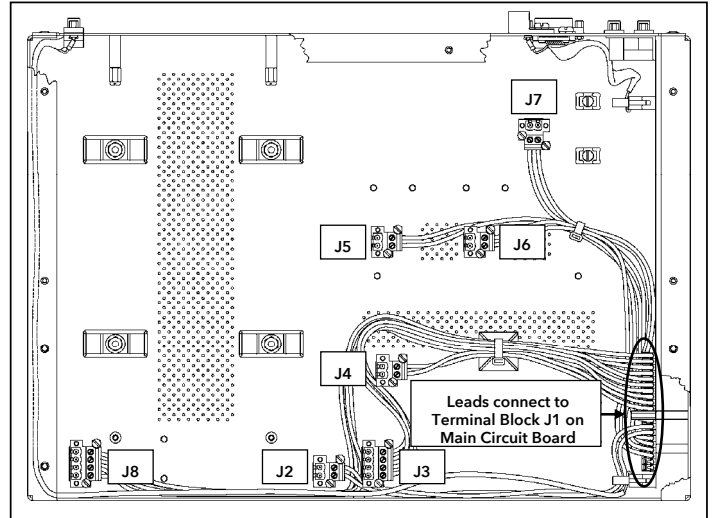
**Figure 13. TERMINAL BLOCK J1.**

19. Using the 1/4" nut driver, carefully remove the two 1/4" stand-offs or thumbscrews securing the circuit board to the chassis. Refer to Figure 14. Retain the stand-offs for re-use.



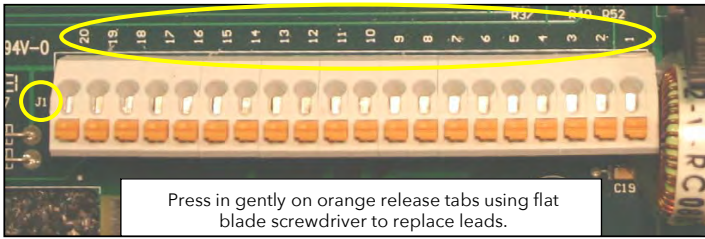
**Figure 14. CIRCUIT BOARD STAND-OFFS.**

20. With all electrical leads and cables and the outlet manifold air hose disconnected from the board, and with the two stand-offs also removed, with both hands, gently pry and lift the main circuit board assembly out of the chassis. When removing the board, pay close attention to the communications ports on the back of the unit as they are, in fact, part of the circuit board assembly. Gently work the board loose and remove it.
21. Remove the new circuit board assembly from its protective sleeve. Holding it by the edges, insert it into the chassis. Carefully align the communications ports and Reset button from the back of the unit so that they all fit together properly.
22. Re-install the two stand-offs removed in step 19 to secure the new circuit board to the chassis. Do not over-tighten stand-offs; torque to 8 in/lb.
23. Using the information in Figures 15 and 16, connect the leads from the internal electrical connectors to terminals 20 through 3 (left to right) on circuit board terminal block J1. Terminals 2 and 1 are not used.



Electrical Connector	Corresponding Assembly
J2	Inlet Solenoid
J3	Air Canister #2
J4	Compressor (Pump)
J5	Outlet Solenoid #1
J6	Outlet Solenoid #2
J7	Evaporator Tray
J8	Air Canister #1

**Figure 15. ELECTRICAL CONNECTORS AND THEIR CORRESPONDING ASSEMBLIES.**

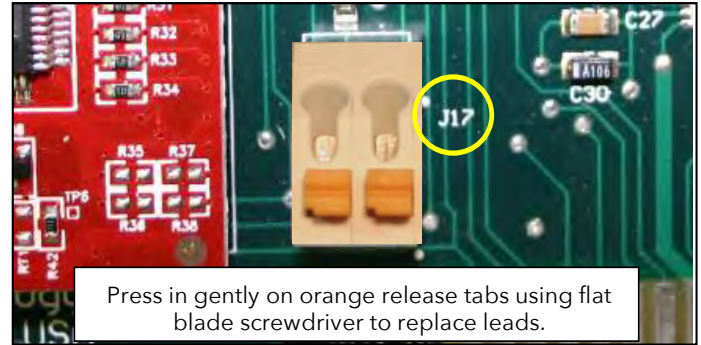


J1 Terminal	Lead Color	Connector / Terminal
20 <sup>1</sup>	White <sup>1</sup>	J8 - 1
19 <sup>1</sup>	White <sup>1</sup>	J8 - 2
18 <sup>2</sup>	Red <sup>2</sup>	J8 - 3
17 <sup>2</sup>	Red <sup>2</sup>	J8 - 4
16 <sup>3</sup>	White / Red Stripe <sup>3</sup>	J3 - 1
15 <sup>3</sup>	White / Red Stripe <sup>3</sup>	J3 - 2
14 <sup>4</sup>	Red / White Stripe <sup>4</sup>	J3 - 3
13 <sup>4</sup>	Red / White Stripe <sup>4</sup>	J3 - 4
12	Black	J4 - 1
11	Red	J4 - 2
10 <sup>5</sup>	Yellow <sup>5</sup>	J7 - 1
9 <sup>5</sup>	Yellow <sup>5</sup>	J7 - 2
8	Gray	J2 - 1
7	Red	J2 - 2
6	Violet	J5 - 1
5	Red	J5 - 2
4	Blue	J6 - 1
3	Red	J6 - 2
2	(Not Used)	-
1	(Not Used)	-

<sup>1,2,3,4,5</sup> Same-colored leads are interchangeable between the two terminals indicated.

**Figure 16. AC/DC TERMINAL BLOCK J1 LEAD CONNECTIONS.**

24. Using the information in Figure 17, connect the leads from the humidity sensor to the terminals on circuit board terminal block J17. Either lead may be connected to either terminal.

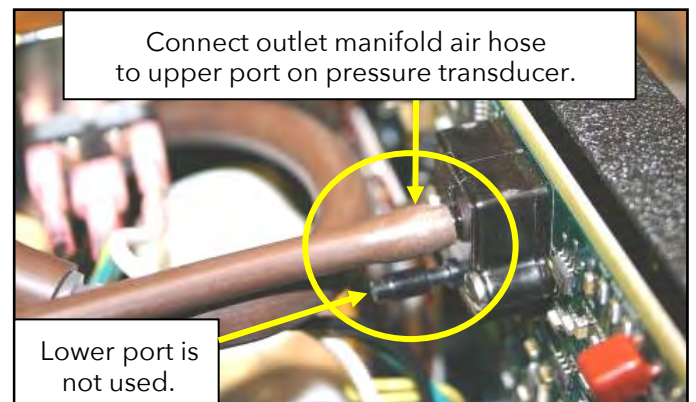


J17 Terminal	Lead Color	Machine Component
Either*	Yellow*	Humidity Sensor
Either*	Yellow*	

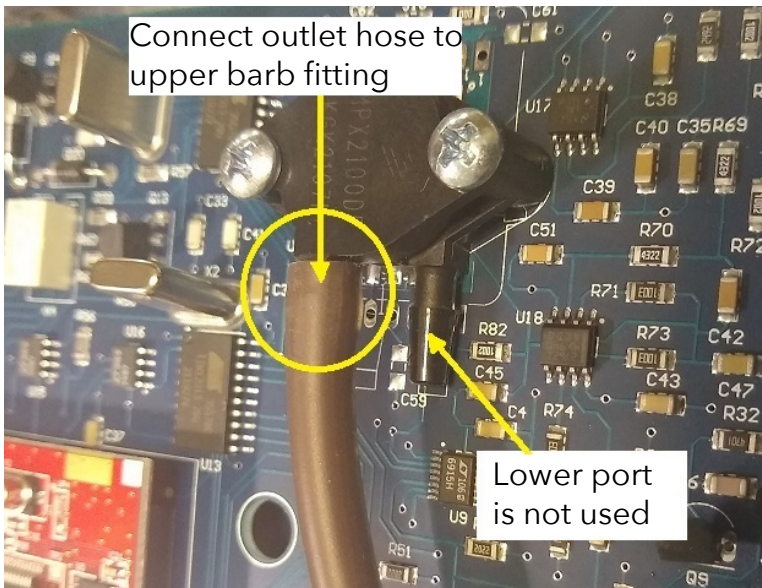
\* Either yellow lead may be installed into either J17 terminal; they are interchangeable.

**Figure 17. TERMINAL BLOCK J17 LEAD CONNECTIONS.**

25. Carefully connect the air hose from the outlet manifold to the upper port on the pressure transducer. Refer to Figures 18 and 18b.

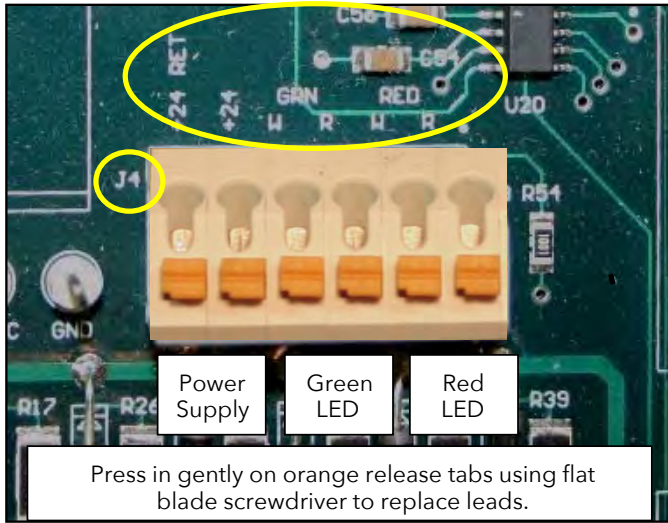


**Figure 18. PRESSURE TRANSDUCER UPPER PORT.**



**Figure 18 b. ALTERNATE PRESSURE TRANSDUCER UPPER PORT.**

26. Reconnect the compressor air hose to the compressor fitting. Refer back to Figure 9 on page 8.
27. Re-install the compressor and its mounting bracket onto the Pem® studs from which they were removed. Secure the mounting bracket using the nuts and lock washers. If using the 2-hole mounting bracket, torque the two nuts to 10 in/lb. If using the 4-hole mounting bracket, torque the four nuts to 8 in/lb.
28. Connect the compressor power connector to the terminal block from which it was removed, then tighten the two end screws to secure it in place.
29. Reinstall the AC power supply module onto the Pem® studs from which it was removed. Secure the module in place using the two nuts and lock washers. Torque to 10 in/lb.
30. Install the three AC power supply leads (white, black, yellow/green) to the terminals from which they were disconnected on the back of the power filter module. Refer back to Figure 6 on page 7. The black lead is on the left, the white lead on the right, and the yellow/green lead is in the middle.
31. Connect the two AC power supply leads (black and red) to the two left-side terminals on J4 from which the original leads were disconnected. Connect them with the black lead on the left (+24 RET) and the red lead on the right (+24). Refer back to Figure 5 on page 7.
32. Reconnect the Alarm Relay cable to the left-side receptacle on the new circuit board and secure in place with the release handles. Refer back to Figure 1b on page 5.
33. If your unit is so equipped, reconnect the "Smart Switch" cable to the upper receptacle on the right side of the circuit board. Reconnect the RS232 cable to the lower receptacle on the right side of the board. Refer back to Figure 1b on page 5.
34. Reinstall the front panel using the mounting hardware removed in step 3. Connect the two sets (four total) of electrical leads from the front panel green and red LEDs to their proper terminals on circuit board terminal block J4 using the information in Figure 19. For both sets of leads, the red leads go on the right and the white leads go on the left



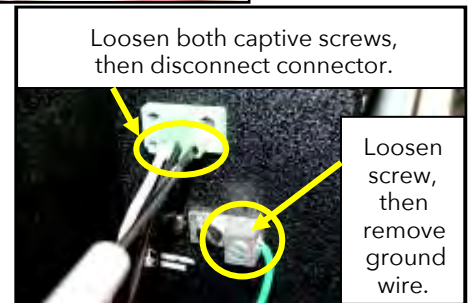
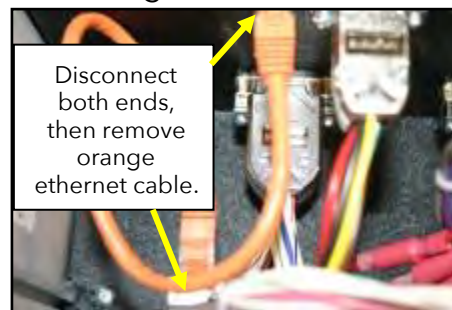
J4 Terminal	Lead Color	Machine Component
+24 RET (Return)	Black	AC Power Supply Module
+24	Red	
GRN W	White	Front Panel Green LED
GRN R	Red	
RED W	White	Front Panel Red LED
RED R	Red	

**Figure 19. TERMINAL BLOCK J4 LEAD CONNECTIONS.**

35. Reinstall both top panels using the hardware removed in step 3.
36. Restore machine power.

**To replace the Main Circuit Board Assembly (23253) in an ADH NETCOM AC NEMA, perform the steps below.**

1. Shut off machine power by unplugging the unit.
2. Open the two front door latches, loosen the two captive screws in the corners of the housing opposite the hinges, then open the NEMA box. Place an object underneath the door once open to help support it during this procedure.
3. Remove the orange ethernet cable on the left by disconnecting both ends, then removing it. Set aside for re-use. Remove the power cable connector on the right by loosening the captive screw on each end of the green connector, then unplugging the connector. Disconnect the ground wire by loosening the ground wire retaining screw, then carefully removing the ground wire. Refer to Figure 1.



**Figure 1. DISCONNECTING THE ETHERNET CABLE, THE POWER CABLE CONNECTOR, AND THE GROUND WIRE.**

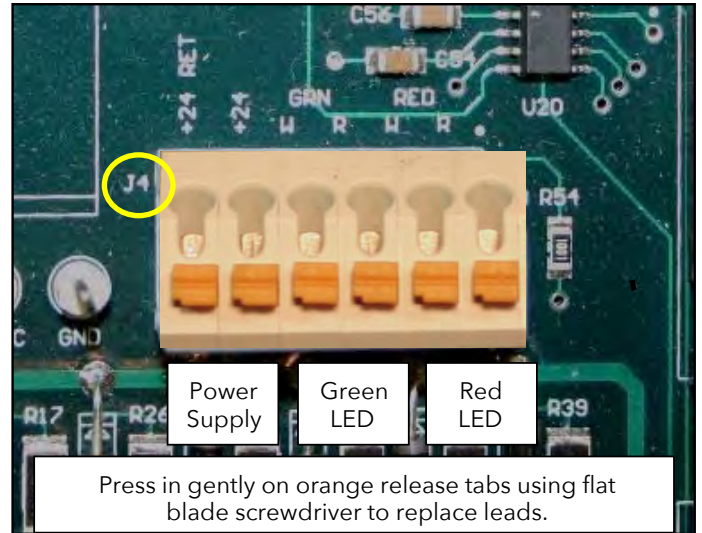
4. Remove and retain the four mounting screws from the four corners of the protective front cover, then slowly lift the front cover, carefully flip it over, then set it down, upside down, to rest on the inside of the enclosure door. Be careful as there are still many wires connected between the enclosure and the front cover and there isn't a lot of slack. Note that the two upper front cover mounting screws are located in plain sight in the top corners of the front cover, while the two lower front cover corner mounting screws are located down in the front "well" of the unit. Use the long Phillips screwdriver to remove them.

5. An Electro-Static Discharge (ESD) wrist strap and mat are required to handle a PC board and perform this procedure safely. If you haven't already done so, put on an ESD wrist strap and work on an ESD mat.

6. Disconnect the "Smart Switch" cable, if your unit has one, and the RS232 cable from the two receptacles on the right side of the circuit board. Refer back to Figure 1b on page 5. The "Smart Switch" cable is the upper one on the right side; the RS232 cable is the lower one. Disconnect the Alarm Relay cable from the receptacle on the left side of the board. Gently fold back the release handles and the cable will disconnect.

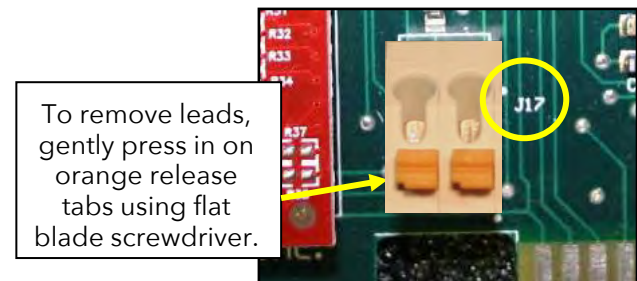
7. Disconnect the two AC power supply module leads (black and red) from the left side of circuit board terminal block J4. Refer to Figure 2 below. Press in on the orange release tabs under each lead, then carefully remove the leads from terminal block J4.

8. Disconnect the two pairs of white and red LED leads (4 total) from the four terminals on the right side of terminal block J4. Refer to Figure 2.



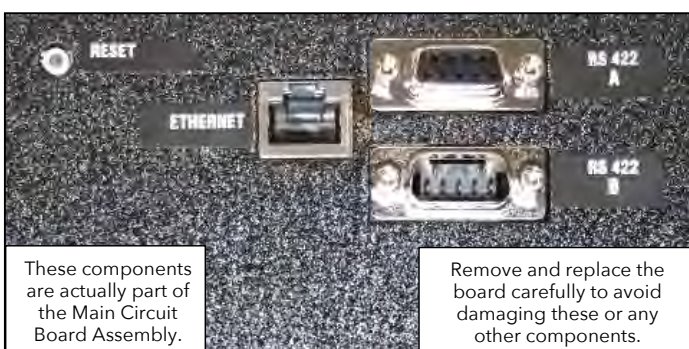
**Figure 2. TERMINAL BLOCK J4.**

9. From circuit board terminal block J17, carefully remove the two yellow leads coming from the humidity sensor. Refer to Figure 3. Use a flat blade screwdriver to gently press in on either orange release tab, then gently remove the lead from the terminal. Repeat for the second lead.



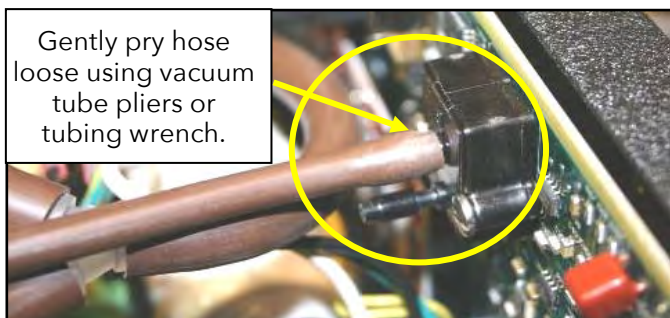
**Figure 3. TERMINAL BLOCK J17.**

10. Both the RS422 A and B communications ports, as well as the Ethernet communications port and the Reset button, are actually all part of the Main Circuit Board Assembly. For that reason, disconnect any cables which might be connected to any of these ports. Refer to Figure 4. It is not necessary to remove either the 15-pin Alarm Relay cable or the 9-pin RS232 communications cable from the back of the unit.



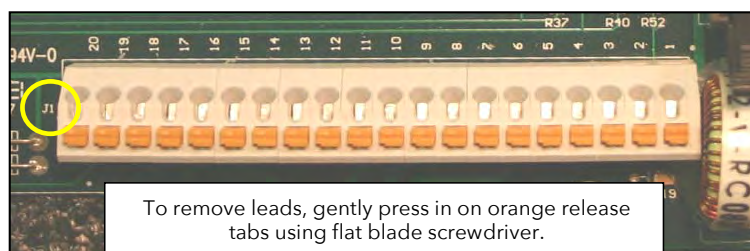
**Figure 4. MAIN CIRCUIT BOARD ASSEMBLY BACK PANEL COMPONENTS.**

11. Using tubing wrench or vacuum tube pliers, gently disconnect the outlet manifold air hose from the upper port of the pressure transducer. Refer to Figure 5. Once disconnected, move the hose out of the way.



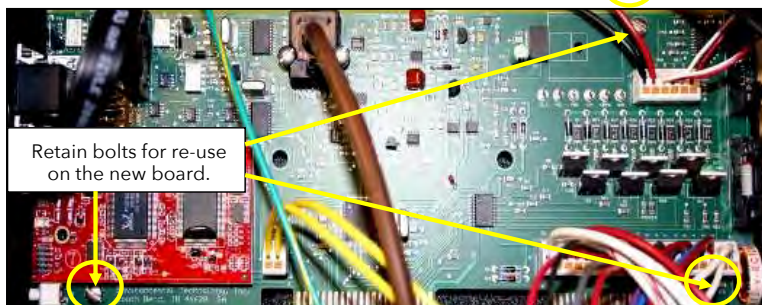
**Figure 5. PRESSURE TRANSDUCER.**

12. From circuit board terminal block J1, carefully remove all the leads connected to it. Refer to Figure 6. Use a flat blade screwdriver to gently press in on each orange release tab, then gently remove the corresponding lead. Disconnect all leads from the terminal block.



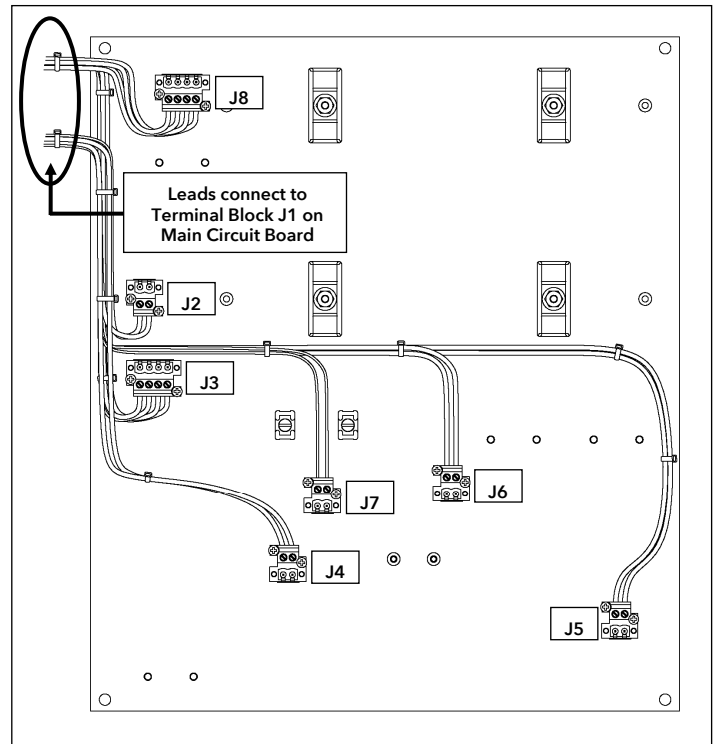
**Figure 6. TERMINAL BLOCK J1.**

13. Remove the three screws securing the circuit board to the chassis. Refer to Figure 7. Retain screws for re-use.



**Figure 7. CIRCUIT BOARD MOUNTING BOLTS.**

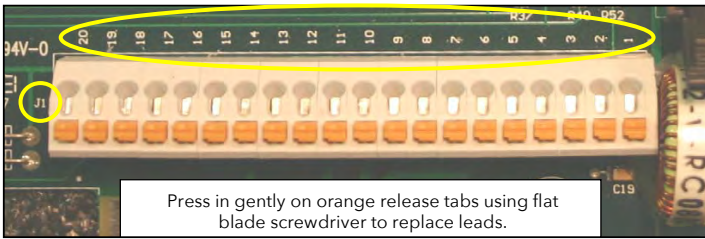
14. With all electrical leads and cables and the outlet manifold air hose disconnected from the board, and with the three mounting screws also removed, with both hands, gently pry and lift the main circuit board out of the chassis. When removing the board, pay close attention to the communications ports on the back of the unit as they are, in fact, part of the circuit board assembly. Gently work the board loose and remove it.
15. Remove the new circuit board assembly from its protective sleeve. Holding it by the edges, insert it into the chassis. Carefully align the communications ports and Reset button from the back of the unit so that they all fit together properly.
16. Re-install the three screws removed in step 13 to secure the new circuit board to the chassis. Do not over-tighten the screws; torque to 8 in/lb.
17. Using the information in Figures 8 and 9, connect the leads from the internal electrical connectors to terminals 20 through 1 (left to right) on circuit board terminal block J1. Terminals 10 and 9 are not used.



Electrical Connector	Corresponding Assembly
J2	Inlet Solenoid
J3	Air Canister #2
J4	Compressor (Pump)
J5	Outlet Solenoid #1
J6	Outlet Solenoid #2
J7	Humidity Sensor
J8	Air Canister #1

**Figure 8. ELECTRICAL CONNECTORS AND THEIR CORRESPONDING ASSEMBLIES.**



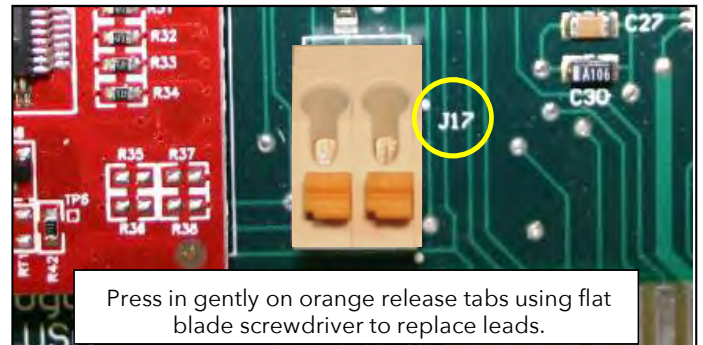


J1 Terminal	Lead Color	Connector / Terminal
20 <sup>1</sup>	White <sup>1</sup>	J8 - 1
19 <sup>1</sup>	White <sup>1</sup>	J8 - 2
18 <sup>2</sup>	Red <sup>2</sup>	J8 - 3
17 <sup>2</sup>	Red <sup>2</sup>	J8 - 4
16 <sup>3</sup>	White / Red Stripe <sup>3</sup>	J3 - 1
15 <sup>3</sup>	White / Red Stripe <sup>3</sup>	J3 - 2
14 <sup>4</sup>	Red / White Stripe <sup>4</sup>	J3 - 3
13 <sup>4</sup>	Red / White Stripe <sup>4</sup>	J3 - 4
12	Black	J4 - 1
11	Red	J4 - 2
10 <sup>5</sup>	Yellow <sup>5</sup>	J7 - 1
9 <sup>5</sup>	Yellow <sup>5</sup>	J7 - 2
8	Gray	J2 - 1
7	Red	J2 - 2
6	Violet	J5 - 1
5	Red	J5 - 2
4	Blue	J6 - 1
3	Red	J6 - 2
2	White <sup>5</sup>	Enclosure Heater
1	White <sup>5</sup>	Enclosure Heater

<sup>1,2,3,4,5</sup> Same-colored leads are interchangeable between the two terminals indicated.

**Figure 9. AC NEMA TERMINAL BLOCK J1 LEAD CONNECTIONS.**

18. Using the information in Figure 10, connect the leads from the humidity sensor to the terminals on terminal block J17. Either yellow lead may be connected to either terminal.

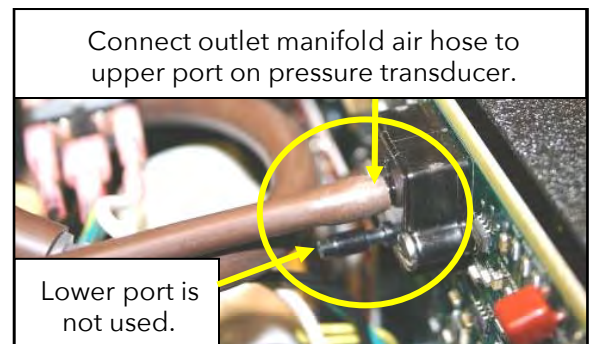


J17 Terminal	Lead Color	Machine Component
Either*	Yellow*	Humidity Sensor
Either*	Yellow*	

\* Either yellow lead may be installed into either J17 terminal; they are interchangeable.

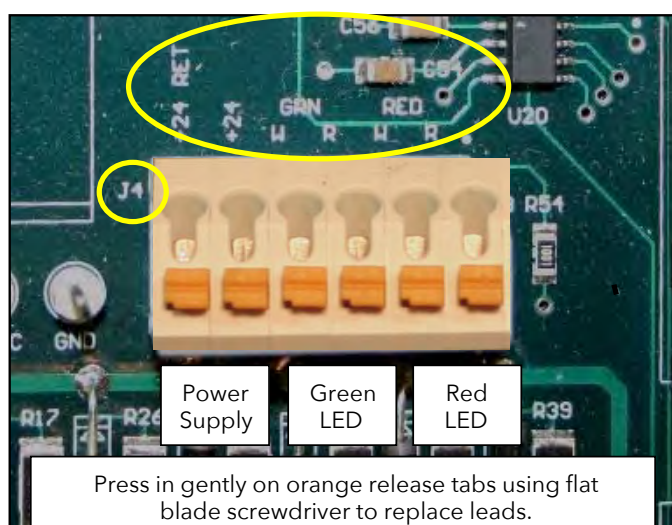
**Figure 10. TERMINAL BLOCK J17 LEAD CONNECTIONS.**

19. Carefully connect the air hose from the outlet manifold to the upper port on the pressure transducer. Refer to Figure 11.



**Figure 11. PRESSURE TRANSDUCER UPPER PORT.**

20. Connect power supply leads to terminal block J4 with the black lead on the left (+24 RET) and the red lead on the right (+24). Refer to Figure 12.
21. Connect the two pairs (four total) of LED leads to their proper terminals on terminal block J4 using the information in Figure 12. For both sets of leads, the red leads go on the right and the white leads go on the left.



J4 Terminal	Lead Color	Machine Component
+24 RET (Return)	Black	AC Power Supply Module
+24	Red	
GRN W	White	Front Panel Green LED
GRN R	Red	
RED W	White	Front Panel Red LED
RED R	Red	

**Figure 12. TERMINAL BLOCK J4 LEAD CONNECTIONS.**

22. Reconnect the Alarm Relay cable to the left-side receptacle on the new circuit board and secure with release handles. Reconnect the RS232 cable to the lower right-side receptacle. If present, reconnect the "Smart Switch" cable to the upper right-side receptacle. Refer back to Figure 1b on page 5.
23. Reinstall the front cover removed in step 4 of this section. Carefully work it into position, past the wires and other components in the enclosure. Reinstall the four corner screws securing the front cover to the chassis.
24. Reconnect the ground wire by inserting it behind the retaining screw from which it was removed, then tighten the retaining screw. Reconnect the green power connector by holding it in place then tightening the two captive screws removed in step 3 of this section. Reconnect both ends of the orange ethernet cable removed in step 3 of this section. It does not matter which end of the ethernet cable goes into which receptacle.
25. With the ground wire, power connector, and ethernet cable reconnected, close NEMA enclosure lid and secure the two latches opposite the hinges. Secure the lid in place by reinstalling the two captive screws in the two outer corners of the lid.
26. Restore machine power by plugging the unit back in.

## QUESTIONS AND COMMENTS

For technical help, questions, or comments concerning this or any ETI, Inc., product, contact the Customer Service Department between 8:00 a.m. and 5:00 p.m. EST.

## DISCLAIMER

ETI, Inc. makes no representations or warranties, either expressed or implied with respect to the contents of this publication or the products that it describes, and specifically disclaims any implied warranties of merchantability or fitness for any particular purpose. ETI, Inc. reserves the right to revise this publication and to make changes and improvements to the products described in this publication without the obligation of ETI, Inc. to notify any person or organization of such revisions, changes or improvements.

No part of this manual may be reproduced or translated in any form or by any means, electronic or mechanical including photocopying and recording, for any purpose without the express written consent of ETI, Inc.

The ETI logo, We Manage Heat, and ADH are registered trademarks of ETI, Inc. NETCOM is a trademark

Copyright © 2012 ETI, Inc. All rights reserved.