

QUICK-REFERENCE INSTALLATION GUIDE

SNOW SWITCH[®] MODEL EUR[™]-5A AUTOMATIC SNOW/ICE MELTING SYSTEM CONTROL PANEL

PACKING LIST

QTY.	PART NO.	DESCRIPTION
1	21496	EUR-5A Snow and Ice Melting Control
1	25076	High Temperature Limit Sensor
1	14257	Power Transformer, 50 VA, 120 V to 24 V
1	21357	RCU-3 Remote Control
1	21184	Fuse Kit
1	25161	EUR-5A Installation Guide (this document)

DETERMINING THE AMOUNT OF SENSORS YOU CAN USE

The EUR-5A has 46 watts of power available for use between the sensors and contactor. The power requirement of your contactor will determine the amount of watts left available for your sensors. After determining your contactor's power requirement, subtract that from the 46 available watts, the result will be your available power for your sensors. You can then take your available power and use that to determine the number of sensors you can use.

- Each CIT-1 aerial sensor (at least one is required) uses 2.4 watts of power

- Each GIT-1 gutter sensor uses 6 watts of power
- Each SIT-6E pavement sensor uses 6 watts of power

At least one CIT-1 Areal sensor is required for an effective snow/ice melt system. Make sure your combined sensor and contactor's power use does not exceed 46 watts.

ENVIRONMENTAL SENSORS

The use of sufficient appropriately-placed environmental sensors is important for effective and efficient system operation. An aerial snow sensor can give the system a head start in protecting against snow or ice buildup, yielding more consistent protection.

QUICK-REFERENCE INSTALLATION GUIDE

INSTALLATION

The system installation with the EUR-5A snow and ice melting control should be performed by a qualified, licensed electrician. The installation and all electrical connections should conform to the NEC (ANSI/NFPA 70) in the United States of American, to the Canadian Electrical Code in Canada, and to all applicable local electrical codes and laws.

The EUR-5A and ETI sensors are Class 2 devices and utilize Class 2 wiring. The EUR-5A should be housed in a protected location that meets local electrical code. The EUR-5A can be mounted in the same panel as the heater contactors, as long as no unrelated circuits are present and the required internal spacings and barriers are implemented. If the EUR-5A needs to be located in an area where it might be exposed to environmental hazards the EUR-5A should be housed in a NEMA enclosure suited for the local environment.

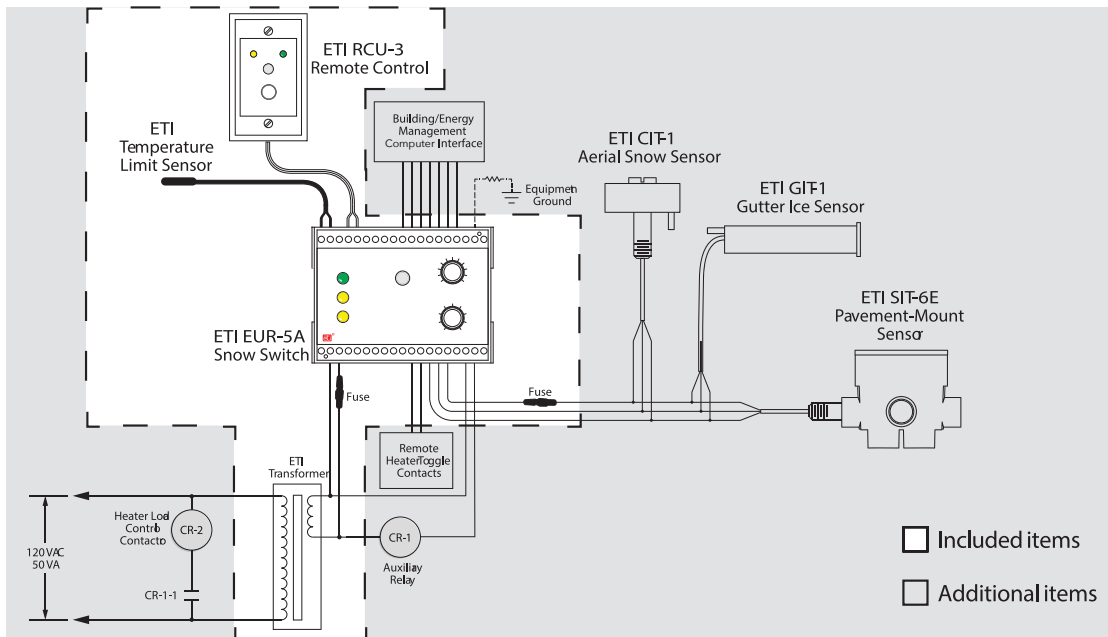
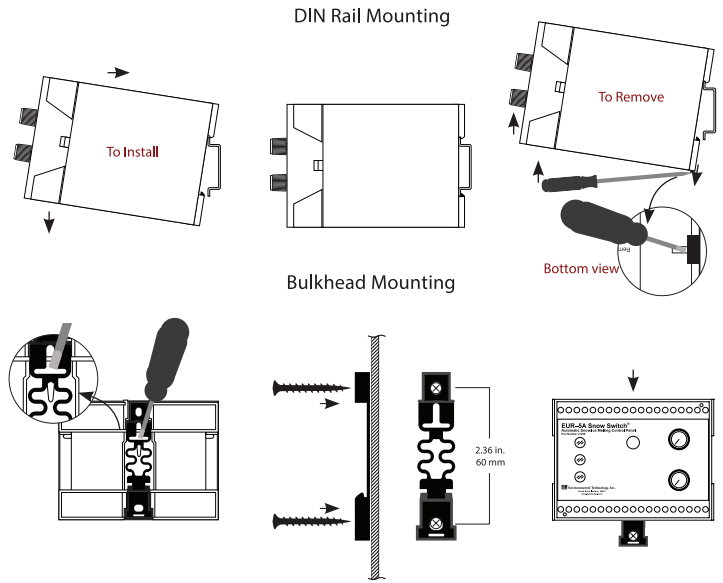

Make sure that your installation and all electrical connections conform to the NEC (ANSI/NFPA 70) in the United States of American, to the Canadian Electrical Code in Canada, and to all applicable local electrical codes and laws. The EUR-5A, RCU-3, and ETI environmental sensor are all rated as NEC Class 2 devices.

QUICK-REFERENCE INSTALLATION GUIDE

1. POWER SOURCE AND CONTACTOR CONNECTIONS (Terminals 21, 22, 36 and 37)

The EUR-5A operates from a 24 VAC NEC Class 2 power source. The optional 120 to 24 volt control transformer is included for use in installations using 120 VAC power.

Figure 5 shows power and contactor connections for a typical installation. Since the EUR-5A is an NEC Class 2 device, it usually requires a customer-supplied auxiliary relay for operating the heater control contactors to separate the Class 2 circuit from the power circuits. In case your installation is different and the necessary connections to the EUR-5A are unclear, Customer Service is available for assistance.

2. INLINE FUSE CONNECTIONS (Terminals 26, and 36)

The supplied inline fuses, rated at 2.0 amps, are used to protect the EUR-5A and its connected devices. Figure 6 shows how these are connected. One of them is in series with the 24-volt supply to the EUR-5A. The other is in series with the 24-volt supply connection to the environmental

sensors that use power (this power source is full-wave rectified). These fuses are necessary to protect the EUR-5A from an overload or short in the sensor or its wiring.

The 24 VAC Return is not ground; a floating ac power source, such as the transformer secondary, is used here.

3. GROUNDING (Terminals 18, or 19)

The EUR-5A sensor circuits and the EMC inputs are referenced to a common circuit ground. In most situations this part of the system can be left floating from the building panel ground (not connected to it). In some cases, noise or transient immunity may be improved if the EUR-5A (with its sensors) is actually grounded to the building ground. But this can create a voltage difference on the sensors because of the difference in the electrical potential of the building ground and the outdoor building structures contacting the sensors creating a ground loop. To avoid this potential ground loop install a resistor, such as 100 ohms, between the EUR-5A ground terminal (18 or 19) and the building panel ground.

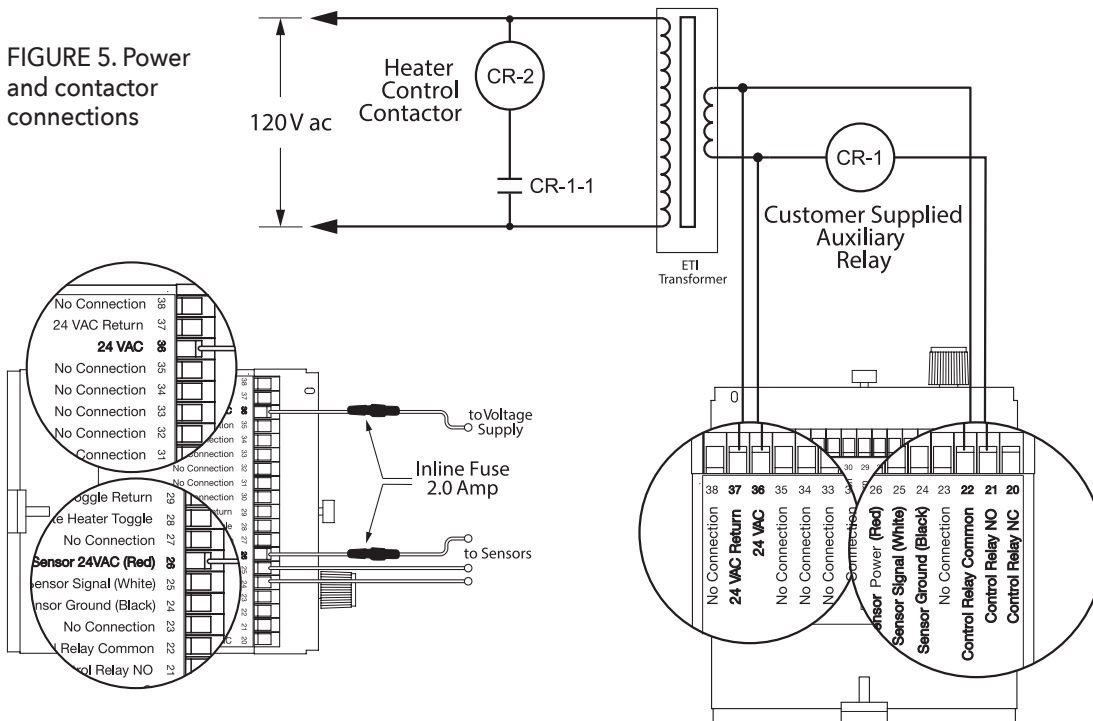

FIGURE 5. Power and contactor connections

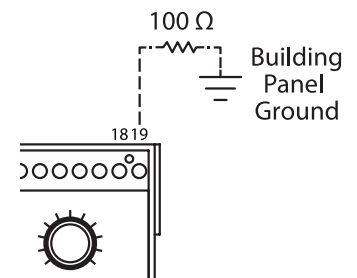

FIGURE 7. EUR-5A unit ground to Building Panel Ground with 100 ohm resistor

QUICK-REFERENCE INSTALLATION GUIDE

4. ENVIRONMENTAL SENSORS

(Terminals 24, 25, and 26)

Sensors are all connected in parallel. Use #18 AWG extension wire for distances up to 1000 ft. (304.8m) and #12 for up to 2000 ft. (609.6m). Running sensor wiring and power line voltage wiring in the same conduit is not recommended.

5. HIGH TEMPERATURE LIMIT SENSOR

(Terminals 1, and 2)

The high temperature limit sensor is connected across terminals 1 and 2. There is no polarity requirement. If the high temperature limit sensor is not used, then a 470k ohm resistor must be connected in its place, across terminals 1 and 2 of the EUR-5A. This is necessary to allow the EUR-5A to operate without the sensor. If the circuit is left open, the Heat indicator on the EUR-5A panel will flash and the control will be disabled.

6. RCU-3 INSTALLATION

(Terminals 4, and 5)

The RCU-3 remote control unit mounts in a single gang switch box. It can be located up to 500 feet (152.4 m) from the EUR-5A at a location convenient for observing snow melting system operation. The RCU-3 connects to the EUR-5A at terminals 4 and 5. There is no polarity requirement.

7. REMOTE HEATER TOGGLE CONNECTIONS

(Terminals 28, and 29)

This is for a user-supplied panel-mounted momentary pushbutton switch for Heater Cycle control. It can be mounted at a location that may be more convenient than the EUR-5A panel. The connections are simply shorted together when the pushbutton is pressed. There is no polarity requirement.

8. ENERGY MANAGEMENT COMPUTER INTERFACE

(Terminals 10, 11, 12, 13, 14, 15, and 16)

The EUR-5A provides three contact-closure outputs to the EMC to indicate operational status with indications of Supply Present, Snow Present, and Heat On. These floating relay contacts share a common connection (terminal 13).

- The SUPPLY PRESENT terminal (14) connects to the common terminal (13) when the EUR-5A is receiving 24- volt power.

- The SNOW PRESENT terminal (15) connects to the common terminal (13) when the sensors report the presence of ice or snow.
- The HEATER ON terminal (16) connects to the common terminal (13) while the heaters are on. When connecting to ECM connect as follows:
- OVERRIDE ON: when the ECM connects terminals 10 and 11 this forces the heaters to be on.
- OVERRIDE OFF: when the ECM connects terminals 10 and 12 this forces the heaters to be off.

CONTACTING CUSTOMER SERVICE

For technical help, questions or comments concerning this product or any ETI product contact Customer Service 8:00 a.m. - 5:00 p.m. EST.

Email: info@networketi.com

Web: networketi.com

Mail: ETI
1850 North Sheridan Street
South Bend, IN 46628

LIMITED WARRANTY

ETI's two year limited warranty covering defects in workmanship and materials applies. Contact Customer Service for complete warranty information.

DISCLAIMER

ETI makes no representations or warranties, either expressed or implied, with respect to the contents of this publication or the products that it describes, and specifically disclaims any implied warranties of merchantability or fitness for any particular purpose. ETI reserves the right to revise this publication, and to make changes and improvements to the products described in this publication, without the obligation of ETI to notify any person or organization of such revisions, changes or improvements.