

# FLOORSTAT® MODEL FWT-3

ELECTRONICS ASSEMBLY/TEMPERATURE SENSOR

## IMPORTANT SAFETY NOTICE

Both the National Electrical Code (NEC) and local codes require using a ground fault circuit interrupter (GFCI) breaker on the branch circuit supplying power to the heating system. This is an essential requirement for shock safety and fire protection. For safe and reliable operation install this control and the heaters in accordance with the suppliers' instructions and in accordance with applicable sections of the NEC and local codes.

## INSTALLATION INSTRUCTIONS

Before disposing of the packing material, verify the inclusion of the following items:

- (1) 18580 FWT-3 Installation and Operation Manual
- (1) 18550 FWT-3 Floorstat Electronics Assembly
- (1) 19272 Temperature Sensor.

Immediately notify CUSTOMER SERVICE of any discrepancy or shipping damage.

The FWT-3 Floorstat mounts in a single-gang switch box (customer supplied). Choose a location that is convenient for the customer. The Temperature Sensor Cable is 25' long and may be extended using #22 (minimum) wire for distances of up to 100'.

Relay Modules are available for 120 or 240 volt 25 amp supply voltages. The heater and Relay Module operate from the same supply voltage. USING A RELAY MODULE HAVING THE WRONG VOLTAGE RATING MAY PERMANENTLY DAMAGE CONTROL COMPONENTS.

Mount a customer supplied 4 square, 21/8" deep, junction box near the floor and close to the heater cold leads. Attach the Relay Module to it. All of the line voltage wiring is enclosed in this junction box. NEC requires heater cold leads to be run in conduit from floor to 4 square junction box.

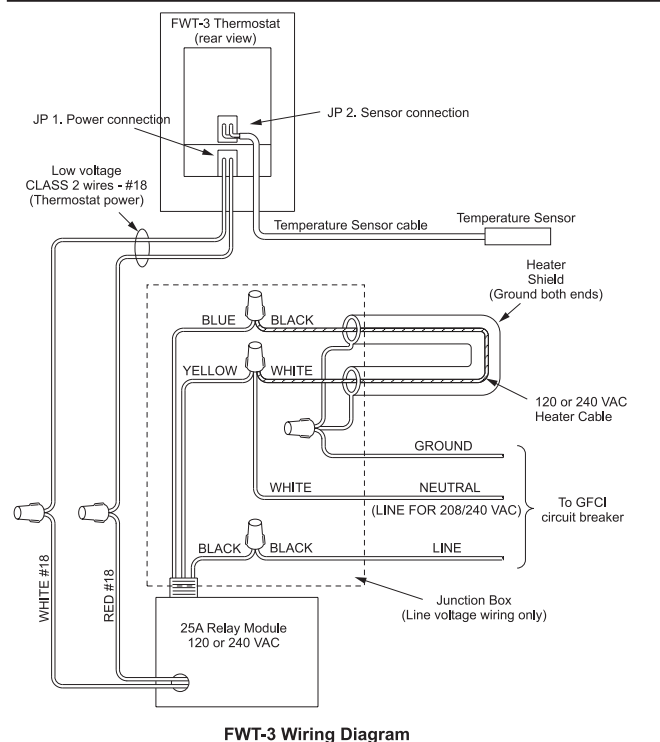
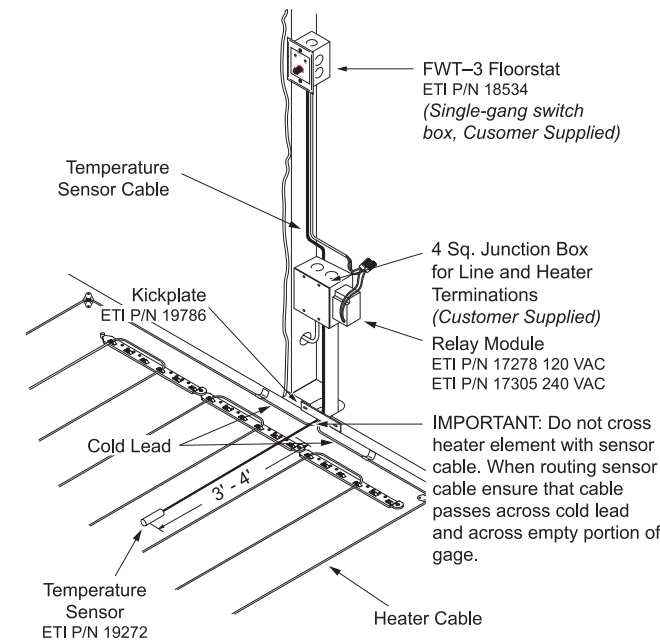

Connect the heater cold lead, line voltage and Relay Module wires together as is shown in the FWT-3 Wiring Diagram. Secure the connections using customer supplied wire nuts. After completing the wiring, install a cover on the junction box.

Connect the Relay Module to JP 1 using two #18 AWG stranded wires. The connection may be made in any order. Secure connections with customer supplied wire nuts.

Place the temperature sensor between heater elements one to two feet from the wall. The sensor extension wire and the heater element must not cross. Connect the Temperature Sensor Cable to JP 2 on the back of the FWT-3. The connection may be made in any order. Secure connections with customer supplied wire nuts.

## OPERATING INSTRUCTIONS

The green SUPPLY indicator operates to show that power is available. The yellow HEATER indicator operates during heating. The knob sets the operating temperature. Clockwise rotation increases the temperature.

Full counterclockwise rotation puts the system in its standby mode which prevents heating. This feature saves energy by not heating unoccupied areas. The SUPPLY indicator blinks continuously to indicate selection of the standby mode.

During normal operation the FWT-3 Floorstat does not require any user intervention. The Digital Anticipation feature provides automatic temperature regulation to minimize temperature swings from solar gain and eliminates any need for a timed set back. When first energized the FWT-3 begins monitoring heater cycles, learning the heating characteristics of the floor, and adjusts subsequent heater cycles to provide the smallest possible fluctuation in floor temperature. The Digital Anticipation takes about two hours to reach an optimal heater cycle. If the FWT-3 loses power it will begin this learning process all over again.

The ETI logo, We Manage Heat, APS and CIT are registered trademarks of Environmental Technology, Inc. EUR is a trademark of Environmental Technology, Inc. Copyright © 2008 Environmental Technology, Inc. All rights reserved.

## TROUBLESHOOTING

### **Neither indicator operates and there is no heat:**

Check the circuit breaker. If tripped, there is either a ground fault or short circuit. If not tripped, either or both the FWT-3 Electronic Assembly or Relay Module are probably defective.

### **Both indicators operate continuously and there is no heat:**

Most likely, either the heater or Relay Module or both are defective. A defective FWT-3 Electronic Assembly is possible but unlikely.

### **Both indicators blink continuously and there is no heat:**

The Temperature Sensor is defective.

### **There is continuous heat and the HEAT indicator is off:**

Either the Relay Module (most likely) or FWT-3 Electronic Module or both are defective.

## LIMITED WARRANTY

ETI's two year limited warranty covering defects in workmanship and materials applies. Contact Customer Service for complete warranty information.

## DISCLAIMER

Environmental Technology, Inc. makes no representations or warranties, either expressed or implied, with respect to the contents of this publication or the products that it describes, and specifically disclaims any implied warranties of merchantability or fitness for any particular purpose. Environmental Technology, Inc. reserves the right to revise this publication, and to make changes and improvements to the products described in this publication, without the obligation of Environmental Technology, Inc. to notify any person or organization of such revisions, changes or improvements.