



**ADH® NETCOM™  
Installation and Operation Manual**

---

**Automatic Air Dehydrator with Ethernet Communications  
Model ADH® NETCOM™**

**Installation and Operation Manual  
Part Number 23526**

**Environmental Technology, Inc.**

1850 North Sheridan Street  
South Bend, Indiana 46628 USA  
(574) 233-1202 or (800) 234-4239  
FAX (574) 233-2152 or (888) 234-4238  
<http://www.networketi.com/>

## **SAFETY INFORMATION AND WARNINGS**

### **Abnormal Odor or Smoke**



In the event of smoke or a burning or abnormal odor, immediately interrupt power to the ADH NETCOM with the POWER switch at the rear of the unit, unplug the unit, or turn off the circuit breaker controlling the outlet. Note that only the AC model of the ADH NETCOM has an ON / OFF switch.

### **Lethal Voltages Present**



Lethal voltages are present inside the ADH NETCOM. Service should be performed by qualified personnel only. There are no user serviceable components inside the chassis.

### **Pneumatics**



Each of the air pumps inside the ADH NETCOM automatic air dehydrator is capable of generating as much as 24 psig (1,655mbar). Other attached dry air sources may be capable of generating even higher pressures. Proper safety practice requires treating all pneumatic components with care. Always vent the system to atmospheric pressure before servicing pneumatic components.

### **Rack Mounting**



Before and after rack mounting the ADH NETCOM, ensure that the rack is stable. Mounting of the ADH NETCOM into a rack should be such that a hazardous condition is not created due to uneven mechanical loading. Verify that adequate air flow and power source capacity is available to the unit. Ensure that the ADH NETCOM maximum operating temperature of 130°F (55°C) will not be compromised by other components in the rack. Ensure reliable earthing of the ADH NETCOM.



## TABLE OF CONTENTS

<b><u>SECTION</u></b>	<b><u>PAGE</u></b>
Safety Information and Warnings -----	2
Unpacking the Unit -----	4
Inventory -----	5
Glossary -----	7
Product Features -----	9
Mean Time Between Failure Statement -----	11
Description and Theory of Operation -----	12
Machine Preparation and Set-Up -----	18
Installation -----	21
Computer Network Communications -----	29
Configuring the System - User Inputs -----	31
Alarms -----	37
Configuring the Alarm Relays -----	39
Operation -----	40
Maintenance -----	41
Troubleshooting -----	42
Replacement Parts -----	57
Specifications -----	58
Appendix A - The ADH NETCOM NEMA Configuration -----	60
Appendix B - Communications Protocols -----	70
Appendix C - Master Configuration -----	81
Ordering Information -----	83

## **UNPACKING THE UNIT**

Immediately upon receipt, inspect the container and packing material for any noticeable damage. Unpack the ADH NETCOM, taking care not to damage the packing materials. Save the shipping container and related materials until normal operation has been established. If the unit must be returned, take care to ensure that it is repackaged as it was received.

As soon as it arrives at your facility, inspect the ADH NETCOM for electrical and mechanical damage. If any of the following problems are found, contact Environmental Technology, Inc., Customer Service immediately:

- contents incomplete or incorrect;
- internal or external mechanical damage; or
- defective operation.

Environmental Technology, Inc., Customer Service is available between 8:00 a.m. and 5:00 p.m. Eastern Time at (574) 233-1202 or (800) 234-4239. In the event of shipping damage, keep the packing materials for inspection by the carrier.

## **RETURNS AND REPLACEMENT PART PURCHASES**

Prior to removal of equipment for return, please contact Environmental Technology, Inc., Technical Support at (800) 234-4239 for troubleshooting assistance.

Before returning an ADH NETCOM to Environmental Technology, Inc., obtain a Return Merchandise Authorization from our Customer Service Department, available between 8:00 a.m. and 5:00 p.m. Eastern Time at (574) 233-1202 or (800) 234-4239. If possible, use the original container and packing materials when packing the ADH NETCOM for shipment. It is important to mark the Return Merchandise Authorization clearly on the outside of the shipping container so that it may be correctly processed upon receipt at Environmental Technology.

For more information about replacement parts or for a replacement Data Sheet or Manual, please visit <http://www.networketi.com/>.

## INVENTORY

Using the information below, verify that the shipping package contains all of the parts listed. If there are any discrepancies, notify Environmental Technology, Inc., Customer Service immediately. Customer Service is available between 8:00 a.m. and 5:00 p.m. Eastern Time at (574) 233-1202 or (800) 234-4239.

Qty.	Part No.	DESCRIPTION
1	23437	ADH NETCOM Automatic Air Dehydrator AC Power Supply
1	23526	ADH NETCOM Instruction Manual (this document)
1	23617	ADH NETCOM Installation Sheet
1	17618	Power Cord, Euro
1	18198	1/8" NPT to 1/4" Barbed Brass Fitting
1	23428	1/8" NPT to 3/8" Barbed Brass Fitting
1	14513	1/8" NPT to 1/4" Barbed Elbow Brass Fitting
4	23245	Mounting Bracket
8	11040	Rack-Mounting Screw (#8-32)
8	10641	#8 Split Washer

**Table 1. PACKING LIST FOR ADH NETCOM, AC MODEL.**

Qty.	Part No.	DESCRIPTION
1	23242	ADH NETCOM Automatic Air Dehydrator DC Redundant Power Supply
1	23526	ADH NETCOM Instruction Manual (this document)
1	23229	ADH NETCOM Installation Sheet
1	18198	1/8" NPT to 1/4" Barbed Brass Fitting
1	23428	1/8" NPT to 3/8" Barbed Brass Fitting
1	14513	1/8" NPT to 1/4" Barbed Elbow Brass Fitting
4	23245	Mounting Bracket
8	11040	Rack-Mounting Screw (#8-32)
8	10641	#8 Split Washer

**Table 2. PACKING LIST FOR ADH NETCOM, DC MODEL.**



**ADH® NETCOM™  
Installation and Operation Manual**

---

<b>Qty.</b>	<b>Part No.</b>	<b>DESCRIPTION</b>
1	23483	ADH NETCOM Automatic Air Dehydrator, NEMA AC Power Supply
1	23526	ADH NETCOM Instruction Manual (this document)
1	23481	ADH NETCOM Installation Sheet
1	18198	1/8" NPT to 1/4" Barbed Brass Fitting
1	23428	1/8" NPT to 3/8" Barbed Brass Fitting
1	23571	Bronze Exhaust Muffler (for use as moisture diffuser)

**Table 3. PACKING LIST FOR ADH NETCOM NEMA, AC MODEL.**

## **GLOSSARY**

Listed below are some important terms and their definitions.

### **Duty Cycle**

The amount of time, expressed as a percentage, that the unit is actually on, cycling, and pumping pressurized dry air.

### **High Duty Cycle Alarm Level**

The configurable set point at which the ADH NETCOM will indicate a high duty cycle. The factory default setting is 50%. The system duty cycle and the discharge pressure are available for display. Typically, the system should be tight enough to limit the duty cycle to less than 20%. System component life decreases as duty cycle increases. A Duty Cycle Alarm occurs if the duty cycle exceeds the configured Duty Cycle Alarm level.

### **High Limit Target Pressure**

The high set point of the operating pressure range for the dehydrator. This is the pressure setting which the unit will target during compressor operation. The actual turn-off pressure is adjusted in the software every pressurization cycle after determining the rate of pressure change during that cycle. This software compensation for the rate of pressure change during pressurization minimizes compressor “undershoot.” The High Limit Target Pressure must be between 0.20 psig and 7.5 psig (14mbar to 517mbar). The factory default setting for High Limit Target Pressure is 0.5 psig (34.5mbar).

### **High Pressure Alarm Level**

The user-configurable high pressure limit at which an alarm condition will be indicated. Note that the High Pressure Alarm Level must be set higher than the High Limit Target Pressure setting. The factory default setting is 1.5 psig (103.5mbar). A High Pressure Alarm occurs if the pressure exceeds the configured High Pressure Alarm Level for more than 30 seconds. Mechanical Overpressure protection is recommended within the system to prevent pressure reaching the High Pressure Alarm level.

### **Low Limit Target Pressure**

The low set point of the operating pressure range for the dehydrator. This is the pressure setting at which the unit will turn off the compressor during compressor operation. The Low Limit Target Pressure must be set lower than the High Limit Target Pressure by at least 0.1 psig (7mbar). The factory default Low Limit Target Pressure is 0.30 psig (21mbar).

### **Low Pressure Alarm Level**

The user-configurable low pressure limit at which an alarm condition will be indicated. Note that the Low Pressure Alarm Level setting must be set lower than the Low Limit Target Pressure setting, and that the factory default setting is 0.15 psig (10mbar). A Low Pressure Alarm occurs if the pressure stays below the configured Low Pressure Alarm Level for more than 30 seconds.

### **Solar Gain**

Generally occurring each day at sunrise, the time when sunlight and heat increase, resulting in a natural corresponding rise in temperature and pressure inside a cable line. Solar gain can also occur before or after a major weather effect.

### **VSWR**

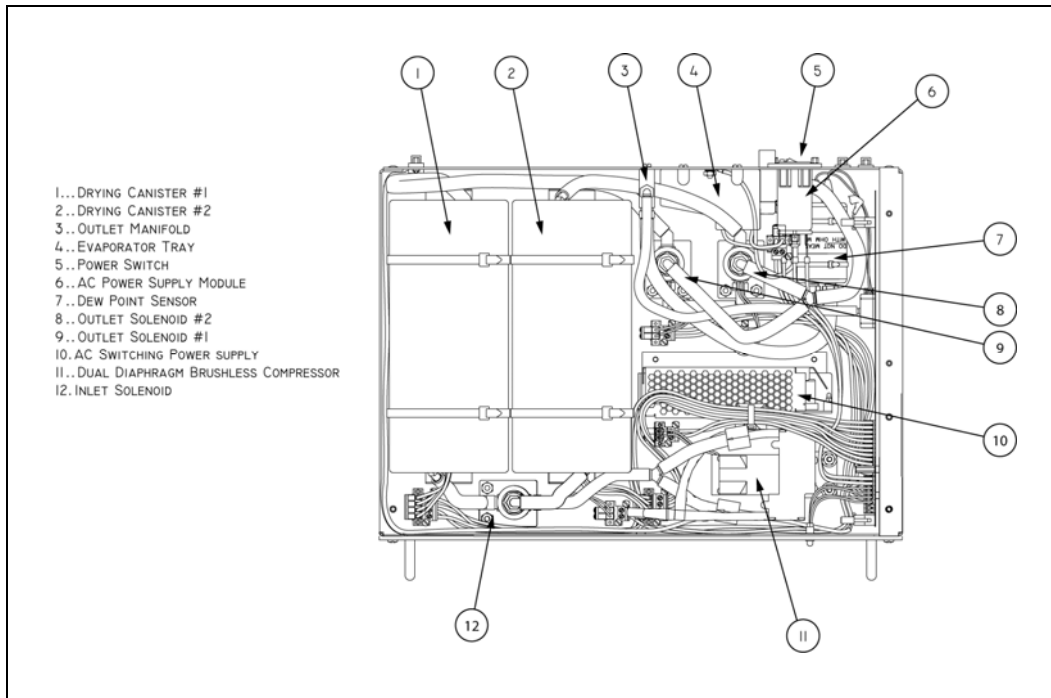
VSWR means Voltage Standing Wave Ratio and is used to measure the amount of energy that is reflected back into the transmitter from the antenna when the antenna is not tuned properly. Water in the transmission line will de-tune the antenna and cause a higher VSWR.

## **PRODUCT FEATURES**

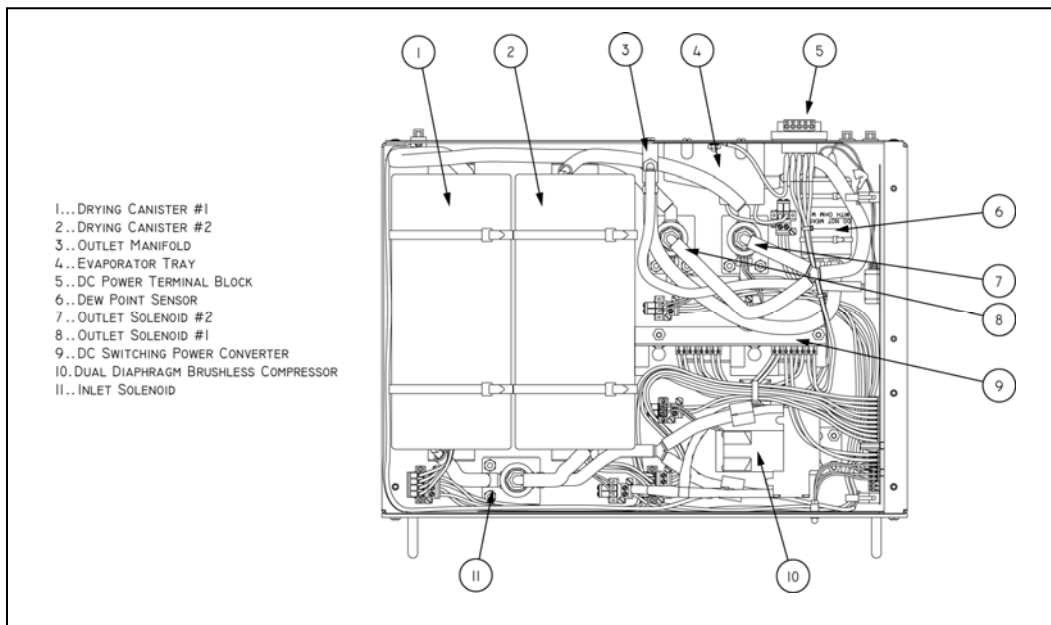
Major features of the ADH NETCOM automatic air dehydrator are listed below. Refer to Figures 1 and 2 for schematic drawings of the ADH NETCOM AC and DC unit configurations.

The ADH NETCOM is functionally equivalent to the earlier ADH-2A COM and the ADH-3COM automatic air dehydrators with regards to basic mechanical features such as air drying and pressurization. The ADH NETCOM automatic air dehydrator offers improved network communications, extended product life expectancy, and simplified ordering and installation. Product features include:

- A drop-in replacement for previous ADH models currently in service
- Similar specifications to earlier ADH models
- 15+ year maintenance-free life expectancy
- Indoor and outdoor mounting options
- 100 to 240 VAC and +/- 20 to 75 VDC power options
- All operational parameters can be easily set by simple web interface
- Communications interfaces include Ethernet networking, RS-422/485, and RS-232
- Network communication protocols include HTTP, SNMP, UDP, and Scientific-Atlanta (S-A)
- Master/slave functionality for automatic operations of paralleled dehydrators
- Interface for the ASM-1 Smart Manifold for automatic operation of one or more antennas from one or more dehydrators
- Complete set of programmable alarms, including three user-configurable alarm relays
- Software can be updated remotely through the network interface, permitting performance updates throughout the life of the dehydrator



**Figure 1. ADH NETCOM AC UNIT COMPONENTS.**



**Figure 2. ADH NETCOM DC UNIT COMPONENTS.**

## MEAN TIME BETWEEN FAILURE STATEMENT

**ADH NETCOM AUTOMATIC AIR DEHYDRATOR  
MEAN TIME BETWEEN FAILURE  
RELIABILITY STATEMENT**

Environmental Technology, Inc., hereby confirms that all original components and spare or replacement parts used in the ADH NETCOM Automatic Air Dehydrator have the reliability characteristics stated below. The ADH NETCOM meets or exceeds our previous generation of automatic air dehydrators in all aspects of fit, form, and function.

ADH NETCOM - Overall Reliability Mean Time Between Failure (MTBF) Rate:  
More than 75,000 hours when maintaining a 5% or lower duty cycle.

**ADH NETCOM AUTOMATIC AIR DEHYDRATOR  
ORIGINAL COMPONENT AND REPLACEMENT PART RELIABILITY LIST**

Item Number	Part Description	Replacement Part Number	MTBF (hours)	Storage (°C)
1	Main Circuit Board	23253	75,000+	-40 to +60
2	Compressor Assembly	23216	160,000+	-40 to +60
3	Absorption Unit (Air Drying Canister)	23218	96,000+	-40 to +60
4	Power Filter Module and Switch (AC)	23446	458,900+	-40 to +60
5	Power Filter Module (NEMA)	23563	458,900+	-40 to +60
6	Discharge Manifold with safety relief valve	23173	100,000+	-40 to +60
7	Solenoid, Right Outlet	23269	150,000+	-40 to +60
8	Solenoid, Left Outlet	23214	150,000+	-40 to +60
9	Solenoid, Inlet	23270	150,000+	-40 to +60
10	Humidity Sensor Assembly	23368	75,000+	-40 to +60
11	Humidity Sensor Assembly (NEMA)	23707	75,000+	-40 to +60
12	ADH NETCOM Manual	23526	–	-40 to +60
13	AC Power Supply Module	23445	420,500+	-40 to +60
14	DC Dual Redundant Power Supply Module	23224	100,000+	-40 to +60

ETI Products and Accessories:

<http://www.networketi.com/products.htm>

Telecom Products and Data Sheets:

<http://www.networketi.com/products.htm>

Telecom manuals:

[http://www.networketi.com/telecom\\_manuals.html](http://www.networketi.com/telecom_manuals.html)

## **DESCRIPTION AND THEORY OF OPERATION**

A detailed product description and theory of operation for the ADH NETCOM automatic air dehydrator are presented below.

### **FUNCTION**

Unpressurized transmission lines allow the entry of moist ambient air through leaking seals and cracks. When the line passes from one environment to another (such as entering a shelter from the antenna outside) or when there is a change in existing environmental conditions (such as a weather front or nightfall) the pressure and/or temperature changes in the air will result in the collection of water inside the line. This is normally the result of the ambient temperature dropping below the dew point. Water in transmission lines causes corrosion, voltage arcing, and increased VSWR, all of which reduce system performance.

The ADH NETCOM automatic air dehydrator prevents the accumulation of moisture in transmission lines by maintaining the pressure and dew point of the air inside the line. Supplying low pressure dry air, the ADH NETCOM keeps waveguides, air-dielectric coaxial cable and related components used in earth station and terrestrial UHF and microwave communication systems dry.

### **PRINCIPAL CONSIDERATIONS**

The ADH NETCOM works best supplying dry air in a flowing system, where the dehydrator completely replaces the air on a regular basis. Consequently, the equipment being supplied dry air should have a bleed system. For a waveguide, this is best accomplished by slightly opening a purge valve at the window end of the system. Installing a pressure relief valve, purposely set higher than the High Limit Target Pressure, will allow the solar pressure gain to bleed off. This will provide for greater system stability and repetitive daily performance and results. Likewise, air dielectric coaxial cable should be equipped with a valve at the far end which can be set to allow a small continuous bleed. Many systems will have sufficient normal leakage that such actions might not be necessary. For optimal performance and life expectancy of the dehydrator a duty cycle between 1% and 10% is recommended.

The ADH NETCOM has check valves in the air path and a pressure relief valve. A tightly sealed system may experience a pressure increase with a rise in ambient temperature. The ADH NETCOM will relieve such build-up should it reach 8 psig (552mbar) but it is advised the ADH NETCOM not be used as the only means of overpressure protection.

## DEHYDRATION SYSTEM

The ADH NETCOM is a low pressure automatic air dehydrator. Low pressure air provides personnel and equipment safety along with energy efficiency. Activated alumina is used as the drying agent. Alumina, or aluminum oxide, is an energy efficient desiccant with a long life expectancy.

Air is dehydrated by passing it through a drying canister containing the drying agent. The dried air is delivered to the communications equipment through a connection in the rear panel. The moisture is removed from the drying canisters by heat. The default configuration provides dry air at 0.5 psig (34.5mbar) and is capable of delivering 26 cubic feet of air per hour (12.3 liters per minute).

Two drying canisters provide a continuous supply of dry air. One unit is active while the other is maintained in stand-by or being regenerated. Under normal circumstances, the dew point of the air is nominally -70°C, with a maximum value of -40°C. The ADH NETCOM will operate on one of the canisters until the canister is wet enough to trip the dew point sensor. When this occurs, the stand-by drying canister is brought into service and the used unit is regenerated. The drying canister being regenerated is heated internally with a resistance heater until a temperature is attained which will convert all absorbed water into steam. The resulting vapor is purged by pumping ambient air through the drying canister and collecting the water in an evaporator where it is again heated and driven off as water vapor. No drain line or special ventilation is needed with standard units. On ADH NETCOM NEMA units, the purge air and steam is evacuated out of the enclosure either by using the bronze muffler (supplied), which serves as a moisture diffuser, or through a customer-supplied drain line via the 1/8" NPT discharge fitting, eliminating moisture from inside the weather-tight enclosure.

## PRESSURIZATION

The dual-diaphragm compressor features a brushless motor with a 15+ year life expectancy. It provides a flow rate of 26 scfh (12.3 l/m). The discharge pressure cycles between two limits. These limits are user-configurable in a range between 0.10 psig and 7.50 psig (7mbar - 517mbar) in 0.01 psig (1mbar) increments. Additional information regarding user-configurable settings is provided later in this manual. A safety relief valve operates at 8 psig (552mbar) to provide over-pressure protection.

A solid state pressure transducer senses discharge pressure. The transducer's signal is digitized and processed to control the compressor. The compressor comes on when the pressure falls below the Minimum Pressure and shuts off at the Maximum Pressure.

Note: If the temperature in the ADH NETCOM automatic air dehydrator is measured at less than 32°F (0°C), the dehydrator will not turn the compressor on. For NEMA units, an enclosure heater will be energized any time the temperature in the dehydrator is below 40°F (4.4°C).

A High Pressure Alarm occurs if the pressure exceeds the configured High Pressure Alarm level for more than 30 seconds. The factory default High Pressure Alarm level is 1.5 psig (103.5mbar). A mechanical pressure safety relief valve provides over pressure protection independent of the electronic system. The set point of the safety relief valve is 8 psig (552mbar).

The compressor duty cycle and the discharge pressure are available over the Ethernet or communications ports. Typically, the system should be tight enough to limit the duty cycle to less than 20%. Dehydrator life decreases as duty cycle increases. A Duty Cycle Alarm occurs if the duty cycle exceeds the configured Duty Cycle Alarm level. The factory default Duty Cycle Alarm level is 50%.

## DISPLAYS

Standard display configuration includes two LED indicators on the front panel for POWER and ALARM. Refer to Figure 3. A web interface provides detailed status information display and allows for unit configuration.



**Figure 3. THE ADH NETCOM FRONT PANEL.**

## COMMUNICATIONS

The ADH NETCOM automatic air dehydrator includes support for both Ethernet network communications and legacy serial communications. The Ethernet capabilities within the ADH NETCOM include support for the web interface, Simple Network Management Protocol (SNMP), User Datagram Protocol (UDP) and Trivial File Transfer Protocol (TFTP). It allows for monitoring and configuration of the dehydrator as well as providing a means for upgrading the dehydrator's software in the field.

The serial capabilities within the ADH NETCOM include legacy support for the Scientific-Atlanta (S-A) protocol used in previous ADH dehydrators. Both RS-422/485 and RS-232 ports are provided for the greatest degree of flexibility.

The ADH NETCOM automatic dehydrator includes three alarm relays for communicating alarm conditions. These are configured at the factory for SUMMARY ALARM, LOW PRESSURE ALARM, and DEW POINT ALARM, but each alarm relay can be user-programmed to any of the alarm conditions tracked by the ADH NETCOM. Each relay has one contact which closes on an alarm condition or loss of power and one contact which opens under the same circumstances. Refer to Table 6 on page 30 of this manual for more information.

## SUPPLY POWER

The ADH NETCOM automatic dehydrator is available in both AC and DC supply power models. AC units have a switching power supply that operates from 100 to 240 VAC, 50/60Hz. DC units have a switching power converter that operates from 20 to 75 VDC with a positive or negative ground system. Neither the AC nor DC units require any customer adjustments to operate within the allowed supply power ranges.

## CANISTER REGENERATION

Drying canister regeneration is controlled by the microprocessor. A thermocouple monitors the temperature of the drying canister. The drying canister is heated until the desired temperature is reached. The drying canister and its contents are allowed to soak at this temperature for approximately two and one-half hours. The drying canister is then purged by pressurized air into the internal evaporator tray, eliminating the need for a drain line.

If the drying canister fails to reach the desired temperature, it is declared dead and an error is issued. The drying canister is allowed six (6) hours to cool. If it fails to cool to less than 18°F (10°C) above the ambient temperature, the unit is declared dead and an error is issued.

## CONDITIONS FOR REGENERATION

The ADH NETCOM automatic dehydrator has two conditions that will mark a drying canister for regeneration: moisture or time.

During normal operation, regeneration begins when the dew point sensor determines that the discharge air from the canister is “wet.” A “wet” condition means a dew point higher than -25°F (-31.7°C), which is still extremely dry air.

The amount of time that a drying canister is in service is recorded by the ADH NETCOM. As a precaution, if a drying canister stays in service for 200 hours, the ADH NETCOM will place that canister into regeneration even though sensed moisture has not reached levels that would be considered wet. This ensures that the drying agent is periodically regenerated even in low dew point conditions to extend the life of the drying agent and ensure peak operation of the dehydrator.

When power is initially applied to the unit, operation begins with the use of one drying canister. The discharge air is monitored for moisture for a short time. The first drying canister is taken out of service and the other drying canister is brought into service. If the first drying canister was determined to be wet, it is placed in a regeneration cycle; otherwise, it is placed in stand-by. The second absorption canister is also tested. If the second drying canister is found to be wet, the first drying canister is brought back into use and the second drying canister is regenerated. The normal regeneration cycle is then entered. If both drying canisters are found to be wet, the drying canister remains in service while the first is regenerated and the dew point alarm is issued.

## SENSORS

The ADH NETCOM automatic air dehydrator has five internal sensors. There are three temperature sensors: the ambient air temperature sensor on the control board, as well as a temperature sensor on the housing of each of the two drying canisters. A fourth sensor, located on the control board, measures the discharge air pressure. The fifth, a dew point sensor, measures the moisture levels in the discharge air.

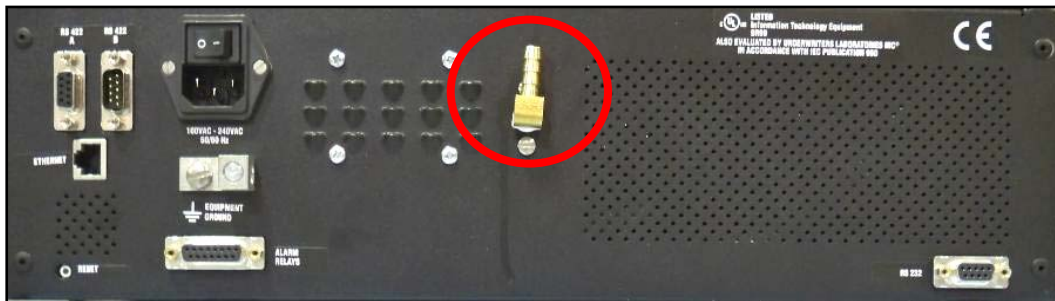
## CONTROL BOARD

The ADH NETCOM utilizes a single control board which includes the microprocessor, the pressure sensor, and I/O connections for both internal control and external communications. The microprocessor controls all internal dehydrator functions. It acts on data collected from various sensors to control operation of the compressor, absorption canister heaters, and solenoid valves. It monitors system operation and generates status and alarm conditions which are communicated via LED indicators (power and summary alarm), programmable alarm relays, serial I/O interfaces (RS-422/485 and RS-232), and through the communications module. The communications module is a plug-in board that controls Ethernet networking including SNMP, the web interface, UDP, and TFTP. The control board includes the pressure sensor and the ambient temperature sensor.

## MACHINE PREPARATION AND SET-UP

Before installing the unit as desired for your site, it is first necessary to connect the proper fitting and air line, as well as the power and desired communications cable(s), on the back panel of the machine.

When connecting an equipment or transmission line to the ADH NETCOM automatic air dehydrator, it is first necessary to install the proper fitting onto the port on the back of the unit. Refer to Figure 4. As described on the Inventory page of this manual, two types of brass fittings are supplied with the unit. They are not interchangeable. The first type, Part Number 18198, connects a 1/8" NPT to a 1/4" barbed fitting. The second type of fitting, Part Number 23428, connects a 1/8" NPT to a 3/8" barbed fitting. Though not required, it is recommended to use the second type of fitting, the one with the 3/8" barbed fitting, on runs longer than one hundred (100) feet or about 30 meters or when using the NETCOM as an input to an ASM<sup>®</sup>-1 Smart Manifold<sup>™</sup> Automated Air Distribution Manifold. Directions for the proper installation of both types of fittings are the same.



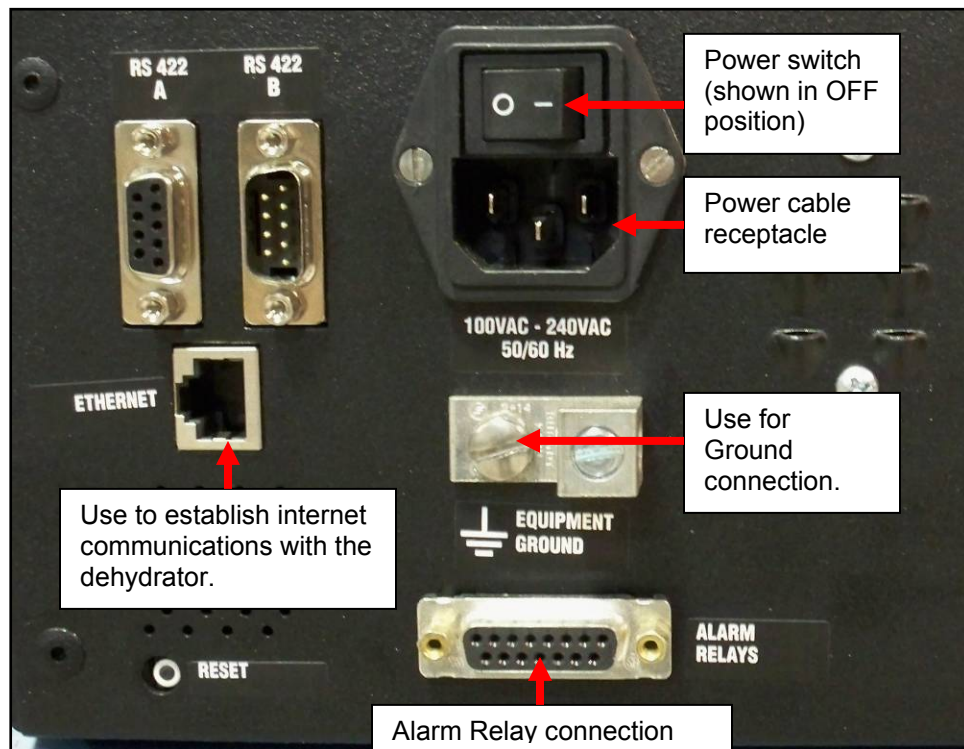
**Figure 4. ADH NETCOM REAR PANEL**  
(with fitting installed).

1. Before installing the fitting onto the back of the dehydrator, first apply some Teflon<sup>®</sup> thread tape (or compatible thread sealant) around the threads of the fitting you will be using. Refer to Figure 5.



**Figure 5. THREAD TAPE ON FITTING.**

2. Install the fitting into the port on the back of the unit. Finger-tighten the fitting into the port. Using a wrench, fully tighten the fitting onto the port. Carefully rotate the fitting with the wrench at least two more turns to the right or clockwise until fully tightened into the back of the unit.
3. Once the brass fitting has been properly installed onto the ADH NETCOM port, secure the air hose in place on the fitting by pressing the hose tightly onto the fitting.
4. Connect the other end of the hose into the fitting on the waveguide flange or the component to be pressurized with dry air.
5. Prior to connecting the unit power cable, first ground the chassis by connecting the ground lead to the Equipment Ground terminal on the back of the unit. Refer to Figure 6. The three-prong power cable (on AC units) also provides ground protection, but this connection provides redundant ground protection for increased safety.



**Figure 6. ADH NETCOM AC VERSION REAR PANEL DETAIL.**

6. For AC units, after connecting the ground wire, make sure that the unit power switch is in the OFF or “O” position, then plug in the power cable to a surge protecting electrical outlet power strip. Leave the power switch in the OFF position. On DC units, there is no power switch so the unit is functional as soon as the DC power cable is connected. Refer to Figure 7.



**Figure 7. ADH NETCOM DC VERSION REAR PANEL DETAIL.**

## CONFIGURING TWO DEHYDRATORS AS MASTER / SLAVE

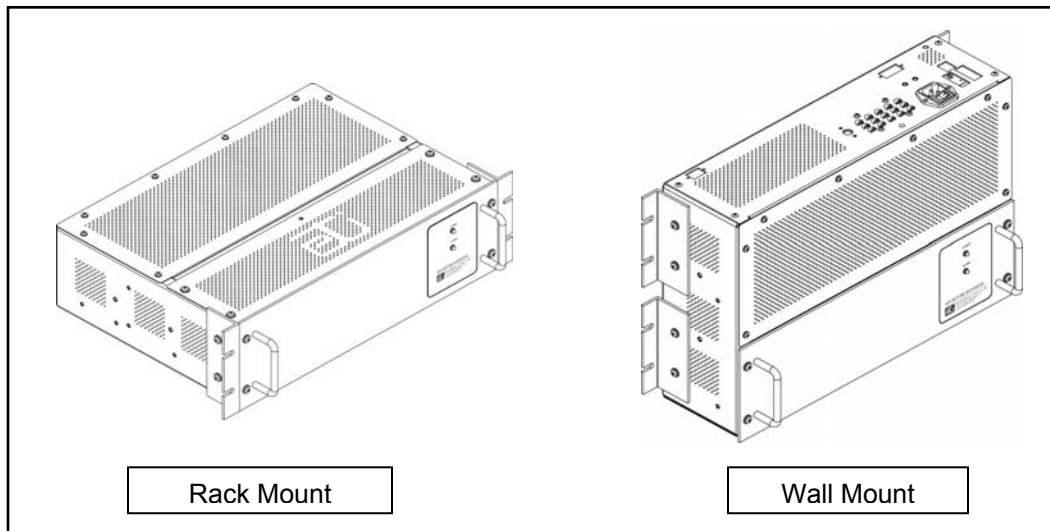
In the Configuring The System section in this manual, instructions will be given on configuring two dehydrators to function with each other as master and slave. To be set up as master and slave, it is not necessary for two dehydrators to be physically connected to each other during the configuration process. However, they must be physically connected to each other following configuration in order to be able to function as master and slave to each other.

Although the Ethernet cable is the preferred means of connecting two dehydrators, if you are trying to establish communications between a new dehydrator and an existing one, or to configure a new dehydrator to function with an existing unit, use the RS-422A/B ports between units to make that connection.

If using the Ethernet connection, typically, both units will be on the same network. However, if they are not, a cross-over cable must be used between the two dehydrators. In the Serial Port Configuration box, use the pull-down menu to establish that connection, referring to the Help screens that appear when the cursor is placed in that field.

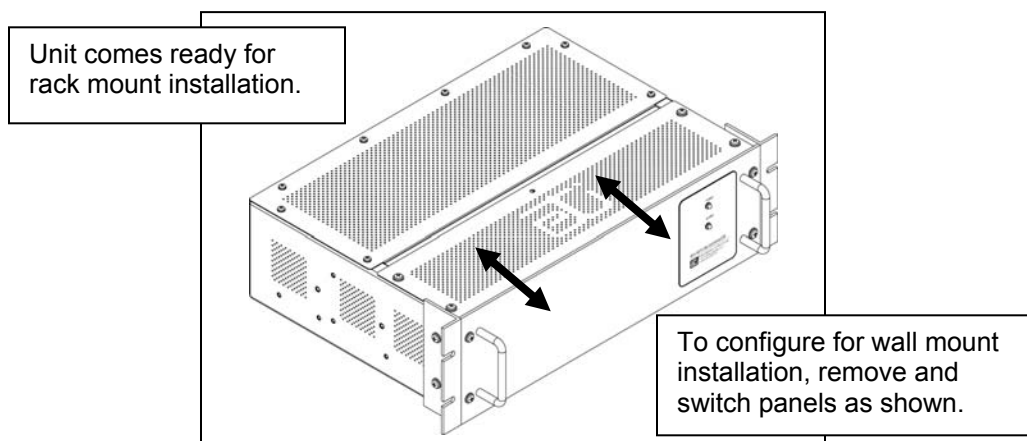
## INSTALLATION

The ADH NETCOM automatic air dehydrator can be rack mounted or mounted to a wall. Refer to Figure 8, as well as the information below.



**Figure 8. A STANDARD ADH NETCOM CONFIGURED FOR RACK MOUNT OR WALL MOUNT INSTALLATION.**

To configure the dehydrator for wall mount installation, remove the front panel and the portion of the vented cover with the ETI logo, then re-install each where the other had been. Reinstall the front panel so that it will be in the new front position once the dehydrator is oriented for wall mounting. Reinstall the small vented panel so that it will be in the new bottom position. Refer to Figure 9.



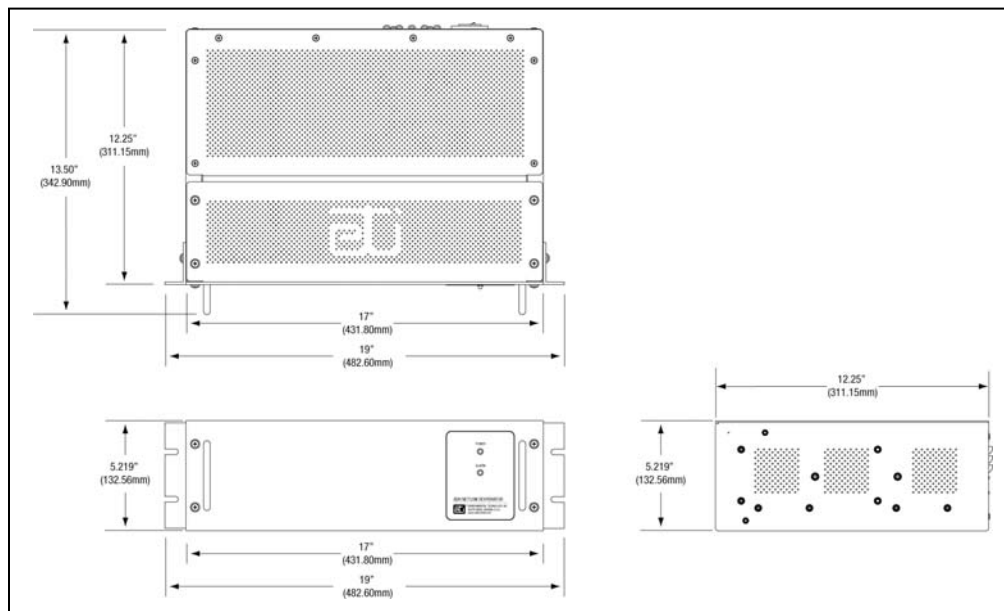
**Figure 9. SWITCHING PANELS FOR INSTALLATION.**

## RACK MOUNTING

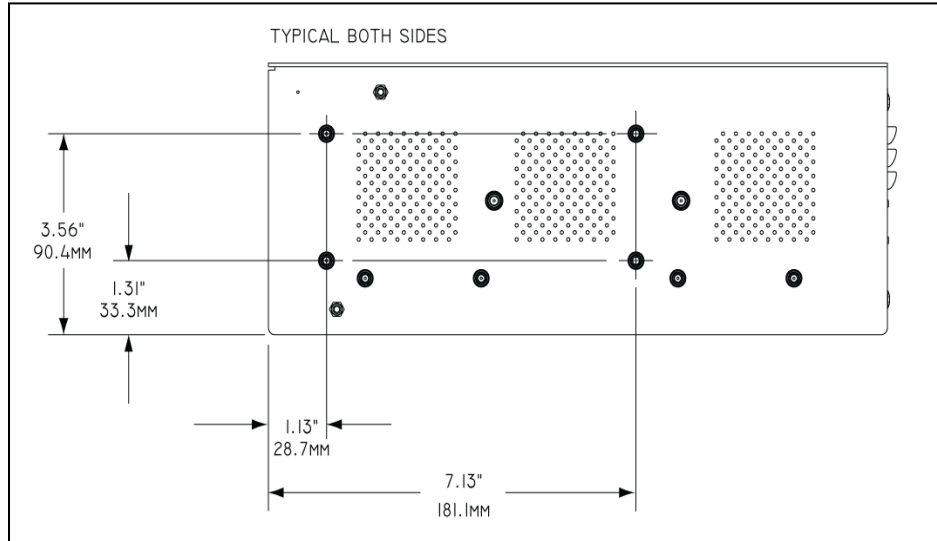
The ADH NETCOM automatic air dehydrator can be mounted in a standard 19" communications rack at one of four depths utilizing two mounting locations. Mounting depths available are flush, 2", 6", and 8". Refer to Figures 10 through 16. The side panels of the chassis contain tapped holes (#8-32) to facilitate installation. The ADH NETCOM automatic dehydrator should be mounted using chassis slide rails (not supplied) or on support channels mounted on the inside of the relay rack. Because the ADH NETCOM seldom requires operator attention, a location in the lower portion or extreme upper portion of the rack may be considered.

### CAUTION

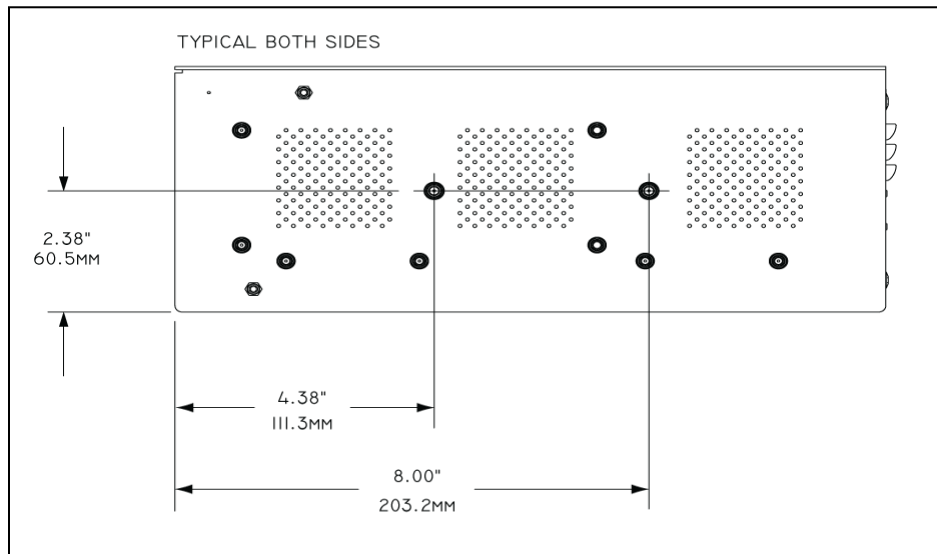
Before and after rack mounting the ADH NETCOM, ensure that the rack is stable. Mounting of the unit into the rack should be such that a hazardous condition is not created due to uneven mechanical loading. Verify that adequate air flow and power supply capacity is available to the unit. Ensure that the maximum operating temperature of 130°F (55°C) will not be compromised by other components in the rack. Ensure reliable earthing of the ADH NETCOM.



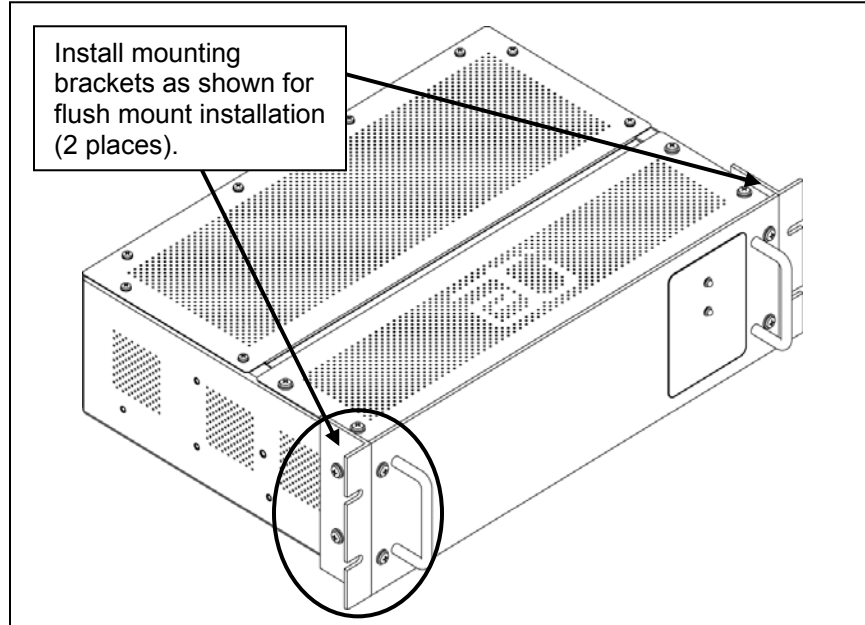
**Figure 10. ADH NETCOM RACK MOUNT DIMENSIONS.**



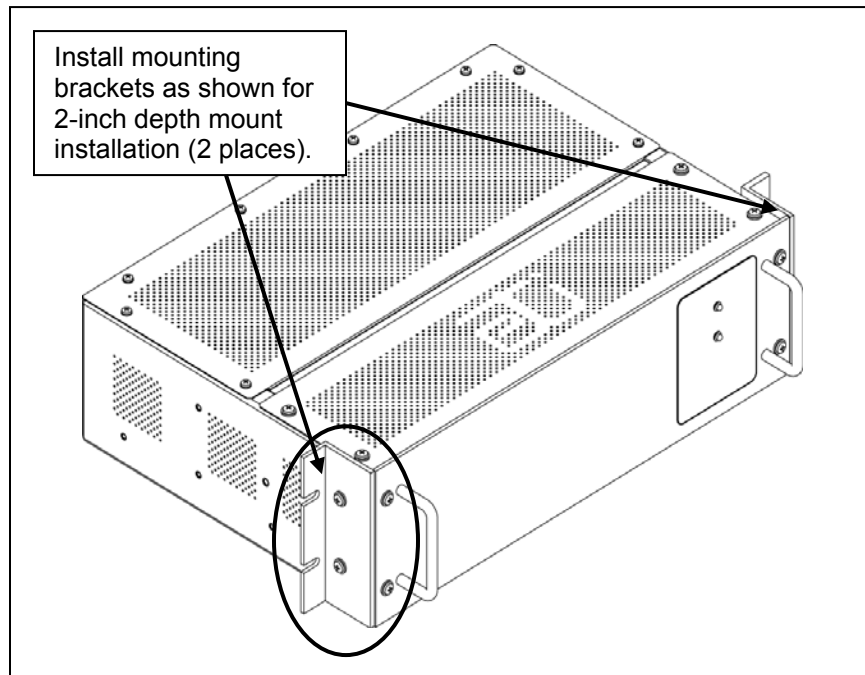
**Figure 11. ADH NETCOM RACK MOUNT HOLE DIMENSIONS.**



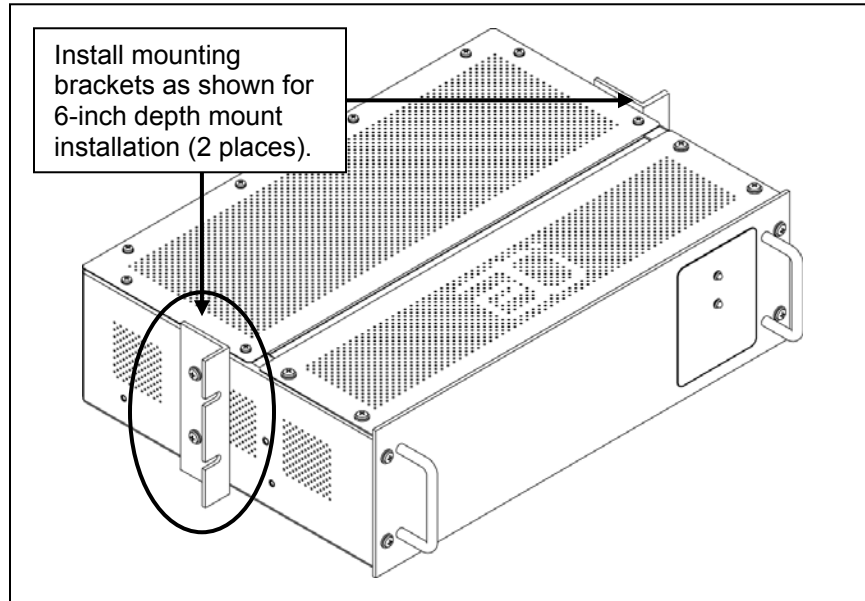
**Figure 12. ADH NETCOM SLIDE RAIL MOUNT HOLE DIMENSIONS.**



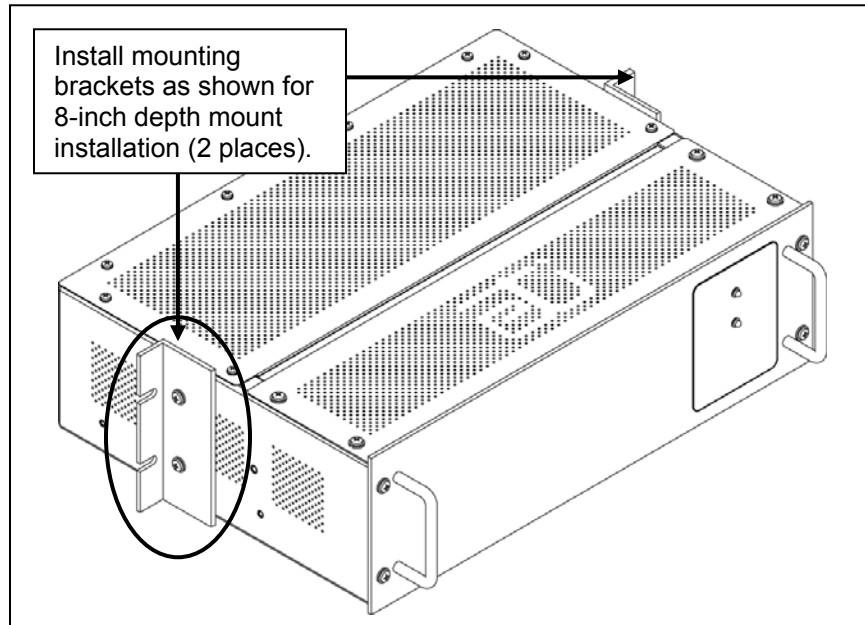
**Figure 13. MOUNTING BRACKETS IN FLUSH MOUNT POSITION.**



**Figure 14. MOUNTING BRACKETS IN 2-INCH DEPTH POSITION.**



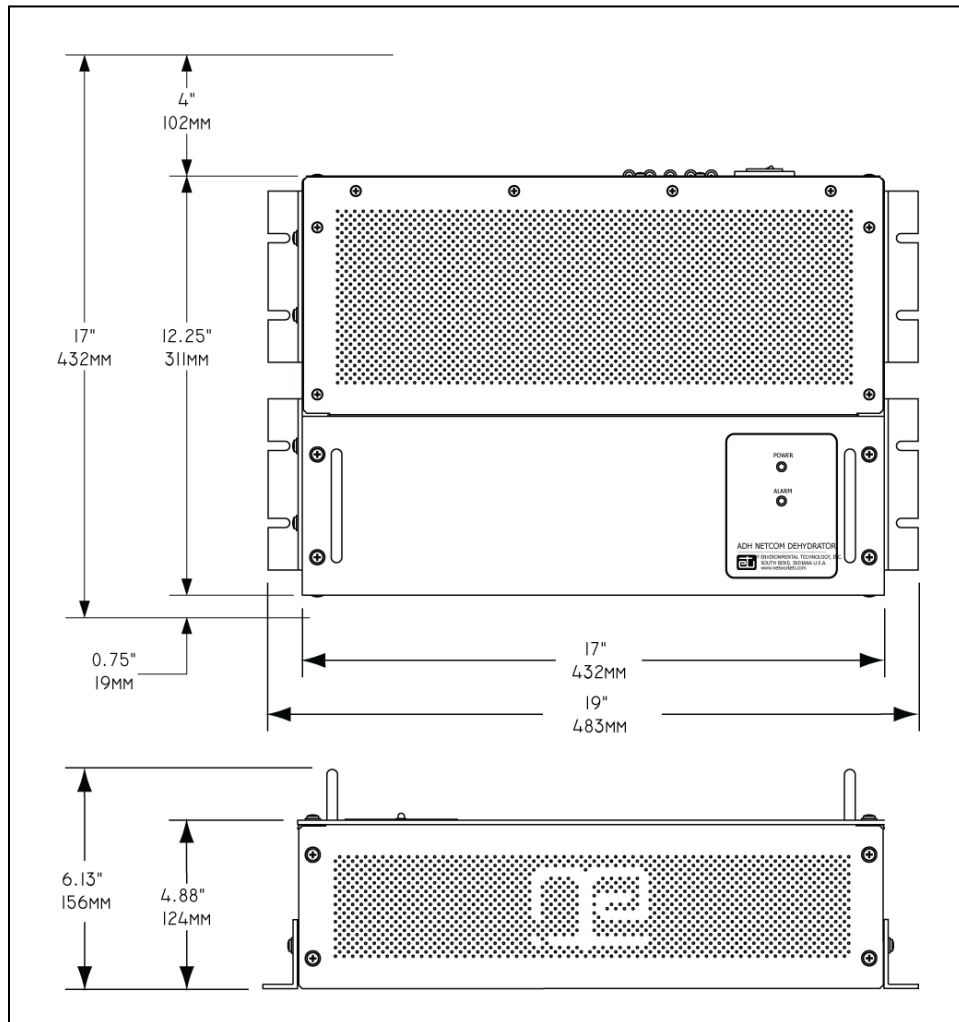
**Figure 15. MOUNTING BRACKETS IN 6-INCH DEPTH POSITION.**



**Figure 16. MOUNTING BRACKETS IN 8-INCH DEPTH POSITION.**

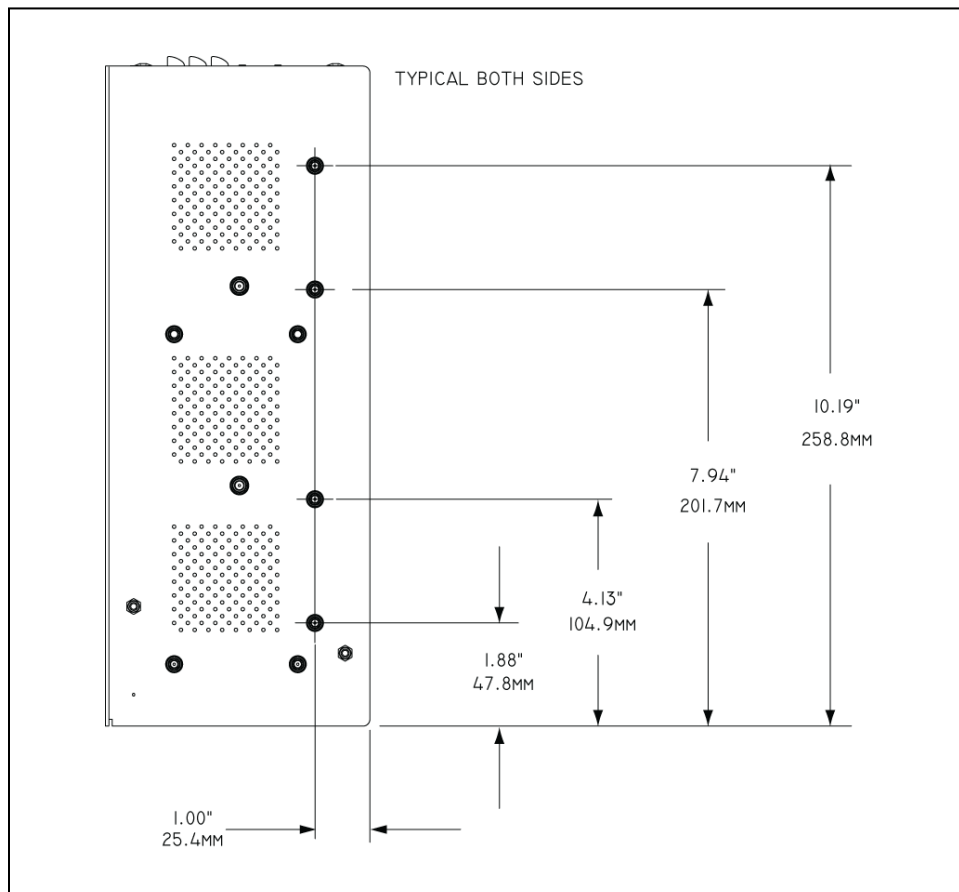
## WALL MOUNTING

Wall mounting an ADH NETCOM requires an area approximately 17" high by 19" wide, and will project almost 6" out from the wall. Refer to Figure 17. Plan your installation so that the ADH NETCOM will not interfere with normal traffic patterns at your site. Ensure that the wall mounted unit has sufficient clearance above the connection panel to facilitate access to the power, communications, and pneumatic interfaces.

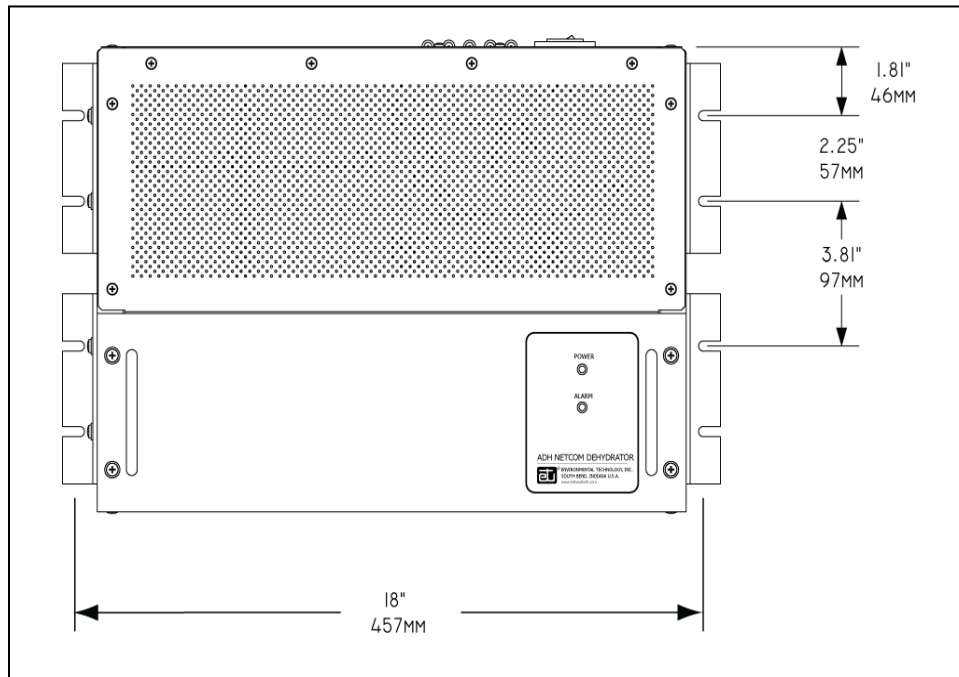


**Figure 17. WALL MOUNT DIMENSIONS.**

To wall mount an ADH NETCOM automatic air dehydrator, all four mounting brackets are used. Refer to Figures 18 and 19. The mounting brackets will accommodate fasteners up to 1/4" (6mm) in diameter. The choice of anchors and companion hardware should be appropriate for the mounting surface. At least four anchors (minimum one per mounting bracket) should be used and each should be capable of supporting at least 16 pounds (7.3 kg). If more than four anchors are used, it is recommended that the combined load capacity be at least 64 pounds (29 kg).



**Figure 18. WALL MOUNT BRACKET HOLE DIMENSIONS.**



**Figure 19. WALL MOUNT POINT DIMENSIONS.**

## POWER CONNECTIONS

For the DC version of the ADH NETCOM, the system can be connected to two independent supplies providing +/-20 to 75 VDC each. Attach to Supply 1 (required) and Supply 2 (optional) as shown on the panel. Attach ground to the ground lug and/or the ground terminal on the terminal block.

### NOTE

The DC version of the ADH NETCOM does not have a power switch. The system will start as soon as power is applied.

The AC version of the ADH NETCOM uses a standard NEMA 5-15P to IEC 320-C13 power cord (included, Part Number 17618). Place the power switch in the OFF position before connecting the power cord.

## COMPUTER NETWORK COMMUNICATIONS

The ADH NETCOM automatic air dehydrator features Ethernet network communications, as well as RS-232 and RS-422/485 serial communications. The primary protocols utilized by the Ethernet communications are SNMP (Simple Network Management Protocol), HTTP (Hypertext Transfer Protocol), UDP (User Datagram Protocol), and TFTP (Trivial File Transfer Protocol). ADH NETCOM communications capabilities allow for monitoring and configuration of the unit, as well as providing a means for upgrading the software in the field.

The factory setting is a fixed IP address of 192.168.52.9, a fixed subnet mask of 255.255.255.0, and a fixed gateway of 192.168.52.1.

The ADH NETCOM includes three alarm relays for external indication of alarm conditions. These are configured at the factory as Summary Alarm, Low Pressure Alarm, and Dew Point Alarm, although each relay can be customer programmed to any of the alarm conditions tracked by the unit.

The ADH NETCOM serial ports use standard DB-9 connectors. Pin outs for the RS-232 are shown in Table 4 below and for the RS-422/485 in Table 5. The Ethernet port uses a standard RJ-45 connector and can use CAT-5 or CAT-5E UTP cable. The alarm relays use a female DB-15 using the pin outs as shown in Table 6 below.

PIN	DESCRIPTION
1	OPEN
2	TX
3	RX
4	DTR
5	GND
6	DSR
7	CTS (Tied to Pin 8)
8	RTS (Tied to Pin 7)
9	OPEN
<b>NOTE:</b> Use straight cable to PC.	

**Table 4. RS-232 PIN DESCRIPTIONS.**

<b>PIN</b>	<b>DESCRIPTION</b>	<b>COMMENTS</b>
1	Shield Ground	
2	Receive Ready	Tied internally to +5 volts via a 4.7K resistor
3	Receive +	Also typically referred to as "R+" or "RB"
4	Transmit +	Also typically referred to as "T+" or "TB"
5	Signal Ground	
6	Transmit -	Also typically referred to as "T-" or "TA"
7	Ready To Send	Pin 7 (RTS) is tied internally to Pin 8 (CTS)
8	Clear To Send	Pin 8 (CTS) is tied internally to Pin 7 (RTS)
9	Receive -	Also typically referred to as "R-" or "RA"

**Table 5. RS-422 PIN DESCRIPTIONS.**

<b>PIN</b>	<b>DESCRIPTION</b>
1	RELAY 1 Closed on alarm
2	RELAY 1 Open on alarm
3	RELAY 2 Closed on alarm
4	RELAY 2 Common
5	RELAY 2 Open on alarm
6	Not used
7	Not used
8	Not used
9	RELAY 1 Common
10	RELAY 3 Common
11	RELAY 3 Open on alarm
12	RELAY 3 Closed on alarm
13	Not used
14	Not used
15	Not used

**Table 6. DB-15 PIN DESCRIPTIONS.**

For additional information regarding ADH NETCOM automatic air dehydrator computer communications, refer to Appendix B in this Manual, Communication Protocols, and Appendix C, Master Configuration Appendix.

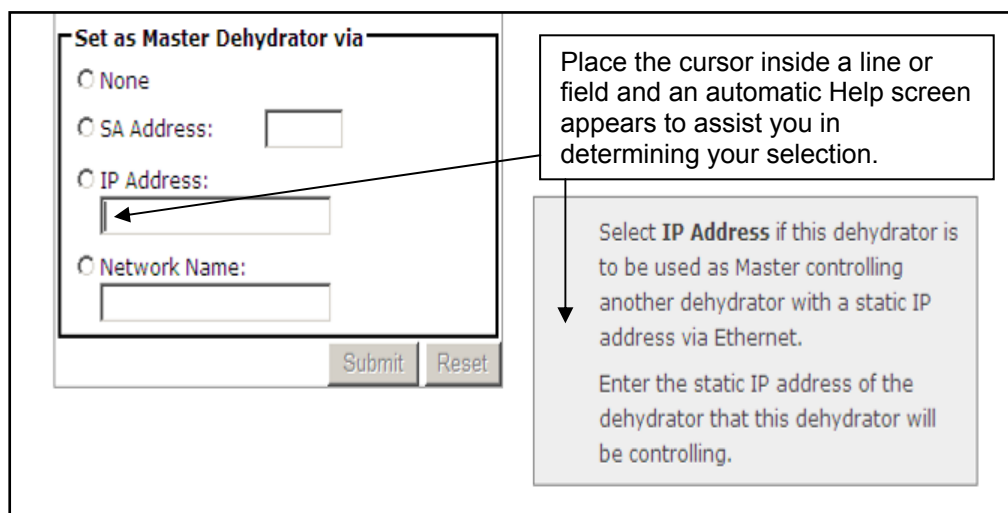
## CONFIGURING THE SYSTEM - USER INPUTS

The ADH NETCOM automatic air dehydrator allows for user configuration of many of its operational parameters. User-configurable alarm settings, along with their default values, are explained in the Alarms section of this Manual.

The ADH NETCOM automatic air dehydrator can be configured and monitored using the simple web interface. Initial set-up is typically done with a standalone PC or laptop computer configured for use in the 192.168.52.0 network. A typical IP address for the configuring host would be 192.168.52.1, with a subnet mask of 255.255.255.0. The initial default IP address of the ADH NETCOM dehydrator is 192.168.52.9 with a subnet mask of 255.255.255.0. Open a web browser and connect to this IP address.

The Configuration page allows users to configure high and low pressure limits and alarms, establish master/slave designations between dehydrator units, set duty cycle and short cycle limits, as well as define the three alarm relays. Also on the Configuration page, the user can configure the serial ports on the back of the unit. There are three ports labeled “RS422A”, RS422B”, and “RS232” on the back of the dehydrator and each can be configured. See Appendix C in this Manual for more information regarding the use of the Scientific-Atlanta protocol.

As shown in Figure 20, when the cursor is placed in many of the fields or lines requiring a setting, a Help screen is automatically displayed, providing useful information and explaining what type of entry or value is required in that field.



**Figure 20. A TYPICAL AUTOMATIC HELP SCREEN.**

The preferred means of configuring the ADH NETCOM automatic air dehydrator is to use the Ethernet cable attached directly to a PC. Follow the steps below.

## COMMUNICATING WITH THE DEHYDRATOR

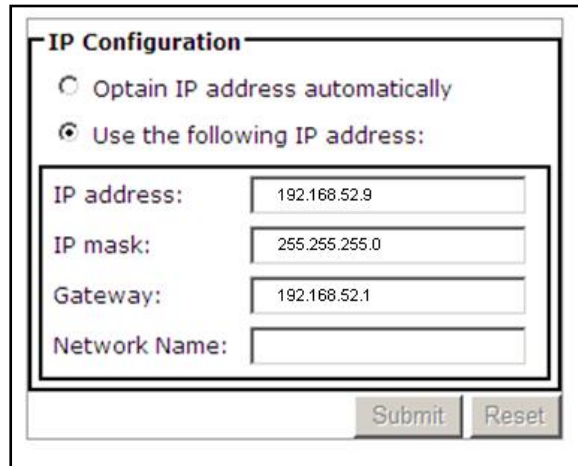
Your Information Technology or IT Department is the best source of information if you encounter problems or difficulties in connecting to or communicating with the dehydrator.

The factory setting is a fixed IP address of 192.168.52.9, a fixed subnet mask of 255.255.255.0, and a fixed gateway of 192.168.52.1.

1. Temporarily assign computer an IP address in the 192.168.52.0 network range, typically 192.168.52.1, with the subnet 255.255.255.0. Note the original configuration so you can restore it when done.
2. Open network connection using web browser via Ethernet connection. If easily available, a cross-over cable or switch is recommended, though a normal Ethernet cable will work fine in most cases.
3. Connect to 192.168.52.9.

## CONFIGURING THE IP ADDRESS

1. Go to the Configuration page.
2. If using a fixed IP address, select “Use the following IP address:” Then, set the IP address, mask, and gateway. Refer to Figure 21.
3. If using DHCP, select “Obtain IP address automatically.”
4. Click Submit. You should see a message that the dehydrator is rebooting, unless the new information is the same as the old.
5. Reconnect to the dehydrator using the new IP address. Also, change the Ethernet cable at the dehydrator to connect to the network instead of the laptop. We recommend powering down the unit while doing this.



**IP Configuration**

Obtain IP address automatically  
 Use the following IP address:

IP address:   
 IP mask:   
 Gateway:   
 Network Name:

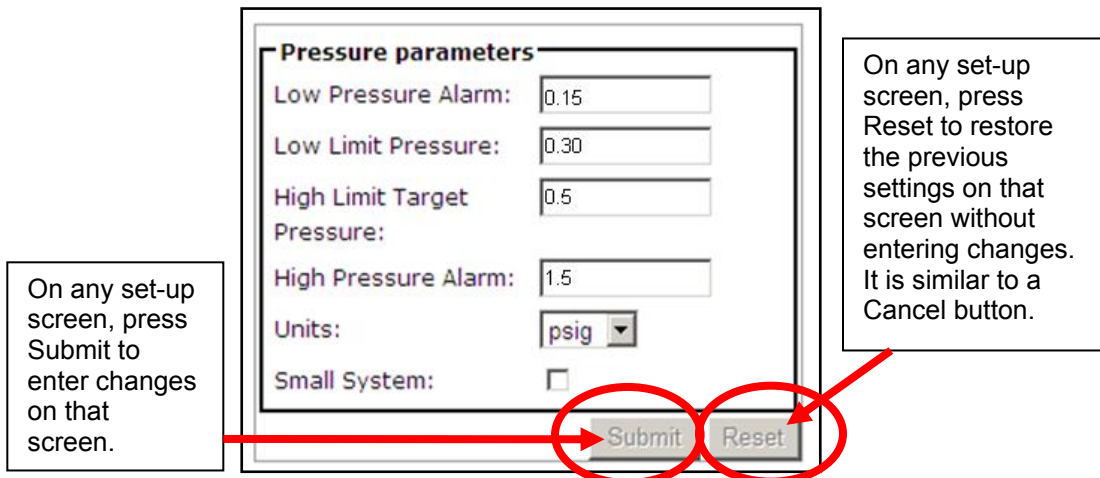
Submit Reset

**Figure 21. THE IP CONFIGURATION SCREEN SHOWING THE DEFAULT SETTINGS.**

- Unless you are going to reconfigure another dehydrator, restore your computer to its original settings.

#### CONFIGURING THE PRESSURE SETTINGS

- Connect to the dehydrator. Go to the Configurations page. Locate the Pressure Parameters screen. Refer to Figure 22.



**Pressure parameters**

Low Pressure Alarm:   
 Low Limit Pressure:   
 High Limit Target Pressure:   
 High Pressure Alarm:   
 Units:   
 Small System:

Submit Reset

On any set-up screen, press Submit to enter changes on that screen.

On any set-up screen, press Reset to restore the previous settings on that screen without entering changes. It is similar to a Cancel button.

**Figure 22. THE PRESSURE PARAMETERS SCREEN SHOWING THE DEFAULT SETTINGS.**

2. Using the Units pull-down, select English (psig) or SI (mbar).
3. To change the current operational pressure settings, enter the following values in the appropriate lines or fields:
  - Low Pressure Alarm - The pressure at which low pressure will cause an alarm condition.
  - Low Limit Target Pressure - The nominal low set point at which the unit will start pumping.
  - High Limit Target Pressure - The nominal high set point at which the unit will stop pumping.
  - High Pressure Alarm - The pressure at which high pressure will cause an alarm condition.

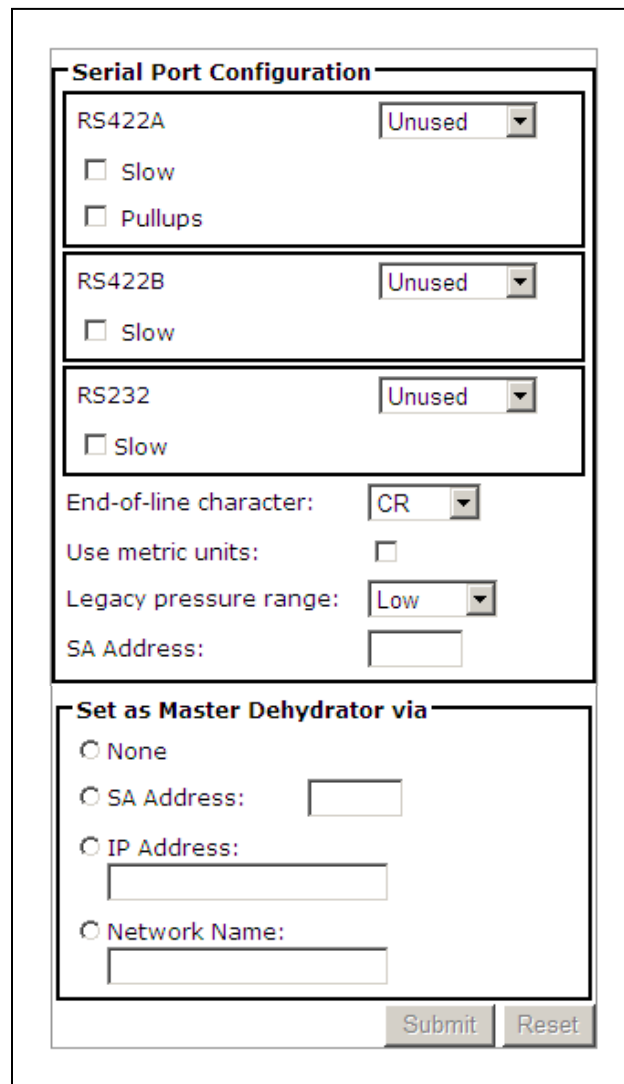
#### SMALL SYSTEM

Small System uses one of the two drying canisters as an additional pressure reservoir. This generally would be used on systems with a total volume of less than 1/2 cubic foot. Select this option, as appropriate, by checking the box.

4. Click Submit for the settings indicated to take effect.

Two dehydrators can be configured so that one controls the operation of the other. To configure one dehydrator to be master over another using the Ethernet connection, perform the steps below.

1. Locate the section of the set-up screens called “Set as Master Dehydrator via” among the several screens on the Configuration page. Refer to Figure 23.



The screenshot displays a configuration interface with two main sections. The top section, titled "Serial Port Configuration", contains three sub-sections for RS422A, RS422B, and RS232. Each sub-section has a dropdown menu set to "Unused" and one or more checkboxes for "Slow" and "Pullups". Below these are settings for "End-of-line character" (set to "CR"), "Use metric units" (unchecked), "Legacy pressure range" (set to "Low"), and "SA Address" (empty text box). The bottom section, titled "Set as Master Dehydrator via", features four radio button options: "None", "SA Address:" (with an empty text box), "IP Address:" (with an empty text box), and "Network Name:" (with an empty text box). At the bottom right of the form are "Submit" and "Reset" buttons.

**Figure 23. THE MASTER DEHYDRATOR SCREEN.**

2. To configure the slave unit, check “None” in the “Set as Master Dehydrator via” box. Click Submit at the bottom for the settings to take effect.
3. To configure the master unit, perform steps 3a through 3c below.
  - 3a. If using either the RS-232 or the RS-422 port, enter the S-A address of the slave unit.
  - 3b. If using a fixed IP address, click the IP address box, then enter the IP address of the slave unit on that line.
  - 3c. If using network names, click the network name box, then enter the network name of the slave unit on that line.
4. Click Submit at the bottom for the settings to take effect.

#### RESET (THE RESET BUTTON)

A Reset button is located on the back panel. This button is used in the event it becomes necessary to reset the unit’s IP address back to its original factory default IP address. The Reset button should never be used during normal operations but only by qualified personnel performing troubleshooting work on the unit. To use the Reset button to reset the unit’s IP address back to the original factory default IP address, perform the steps below.

1. Turn off power to the unit. Because there is no On/Off power switch on the NEMA unit, for this procedure, leave the power cable wires attached to their respective terminal lugs and loosen, but do not remove, the two screws located above the terminal lugs. Holding the wires, gently pull the terminal lug assembly away from the unit and the power will shut off.
2. Press and hold the Reset button on the connection panel. While still pressing the Reset button, turn unit power back on by putting the terminal lug assembly back in place until unit power is restored.
3. Once the power is restored, continue to hold down the Reset button until the two indicator lights on the front panel (Power and Alarm) stop flashing. This usually takes about five seconds.
4. When the indicator lights on the front panel stop flashing, the unit’s IP address will have been changed. Release the Reset button and tighten the two terminal lug assembly screws loosened in step 1 above.

## ALARMS

The ADH NETCOM automatic air dehydrator alerts the user to a variety of alarm conditions. These conditions are described below. Most alarm condition parameters are configurable by the user. Before listing all of the various alarm conditions, it is useful to first explain the user-configurable alarm conditions that can affect or impact dehydrator performance most often. You may also refer to the Glossary at the front of this Manual for additional information.

### USER-DEFINED ALARM VARIABLES

**High Pressure Alarm Level** - The user-configurable high pressure limit at which an alarm condition will be indicated. Note that the High Pressure Alarm Level must be set higher than the High Limit Target Pressure setting, and that the factory default setting is 1.5 psig, or 103.5mbar. A High Pressure Alarm occurs if the pressure exceeds the configured High Pressure Alarm Level for more than 30 seconds.

**Low Pressure Alarm Level** - The user-configurable low pressure limit at which an alarm condition will be indicated. Note that the Low Pressure Alarm Level setting must be set lower than the Low Limit Target Pressure setting, and that the factory default setting is 0.15 psig or 10mbar. A Low Pressure Alarm occurs if the pressure stays below the configured Low Pressure Alarm Level for more than 30 seconds.

**High Duty Cycle Alarm Level** - The configurable set point at which the unit will indicate a high duty cycle. The factory default setting is 50%. The system duty cycle and the discharge pressure are available for display. Typically, the system should be tight enough to limit the duty cycle to less than 20%. System component life decreases as duty cycle increases. A Duty Cycle Alarm occurs if the duty cycle exceeds the configured Duty Cycle Alarm level.

ADH NETCOM alarm and warning conditions are presented in Table 7 on the next page. The numbers associated with each specific condition are used again in the Troubleshooting section of this manual to help connect the indicated condition with an appropriate solution. In Table 7, an “A” designates an Alarm condition, while “W” designates a Warning condition. Remember, however, that these designations are really more a function of “backward” software compatibility with earlier dehydrator models and that the indication of any condition, whether an alarm or a warning, needs to be addressed and corrected as soon as possible.

<b>FLOW CHART SLIDE</b>	<b>ALARM / WARNING NUMBER</b>	<b>ALARM DEFINITION</b>
3	A1	Low Pressure
4	A2	High Pressure
3	W3	High Duty Cycle
5	W4	High Temperature
5	W5	Low Temperature
-	W6	Unused
6	A7	Canister 1 Won't Heat
7	A8	Canister 1 Won't Cool
6	A9	Canister 2 Won't Heat
7	A10	Canister 2 Won't Cool
3	A11	Unable to Pressurize
8	A12	Dew Point Alarm
-	W13	Unused
9	W14	Communications Error (Master units only)
6	A15	Canister 1 Thermistor Bad
6	A16	Canister 2 Thermistor Bad
5	A17	Ambient Thermistor Bad
4	A18	Overpressure
11	A19	Bad Calibrations in EEPROM
11	A20	Bad Limits in EEPROM
12	A21	Short Cycling
13	A22	Pump Shutdown Due To Error Condition

**Table 7. ADH NETCOM ALARMS (A) AND WARNINGS (W) AND THEIR DEFINITIONS.**

In Table 7 above, the number of the Flow Chart Slide corresponds to the number of the Flow Chart in the Troubleshooting section of this manual.

## CONFIGURING THE ALARM RELAYS

Use the following screen to configure the three alarm relays as desired.

**Alarm Relays**

This dehydrator has three relays for annunciating alarm conditions. Select the alarms below that you wish to associate with each alarm relay.

	<b>1</b>	<b>2</b>	<b>3</b>
1: Low Pressure	<input type="checkbox"/>	<input type="checkbox"/>	<input type="checkbox"/>
2: High Pressure	<input type="checkbox"/>	<input type="checkbox"/>	<input type="checkbox"/>
3: Leaky (high duty cycle)	<input type="checkbox"/>	<input type="checkbox"/>	<input type="checkbox"/>
4: Too Hot	<input type="checkbox"/>	<input type="checkbox"/>	<input type="checkbox"/>
5: Too Cold	<input type="checkbox"/>	<input type="checkbox"/>	<input type="checkbox"/>
6: Not used	<input checked="" type="checkbox"/>	<input checked="" type="checkbox"/>	<input checked="" type="checkbox"/>
7: Canister 1 Won't Heat	<input type="checkbox"/>	<input type="checkbox"/>	<input type="checkbox"/>
8: Canister 1 Won't Cool	<input type="checkbox"/>	<input type="checkbox"/>	<input type="checkbox"/>
9: Canister 2 Won't Heat	<input type="checkbox"/>	<input type="checkbox"/>	<input type="checkbox"/>
10: Canister 2 Won't Cool	<input type="checkbox"/>	<input type="checkbox"/>	<input type="checkbox"/>
11: Very Leaky (Shut Down)	<input type="checkbox"/>	<input type="checkbox"/>	<input type="checkbox"/>
12: Dew Point Alarm	<input type="checkbox"/>	<input type="checkbox"/>	<input type="checkbox"/>
13: Not used	<input checked="" type="checkbox"/>	<input checked="" type="checkbox"/>	<input checked="" type="checkbox"/>
14: Communications Error	<input type="checkbox"/>	<input type="checkbox"/>	<input type="checkbox"/>
15: Canister 1 Thermistor Bad	<input type="checkbox"/>	<input type="checkbox"/>	<input type="checkbox"/>
16: Canister 2 Thermistor Bad	<input type="checkbox"/>	<input type="checkbox"/>	<input type="checkbox"/>
17: Ambient Thermistor Bad	<input type="checkbox"/>	<input type="checkbox"/>	<input type="checkbox"/>
18: Overpressure	<input type="checkbox"/>	<input type="checkbox"/>	<input type="checkbox"/>
19: Calibration Corrupted	<input type="checkbox"/>	<input type="checkbox"/>	<input type="checkbox"/>
20: Pressure Limits Corrupted	<input type="checkbox"/>	<input type="checkbox"/>	<input type="checkbox"/>
21: Short Duty Cycle	<input type="checkbox"/>	<input type="checkbox"/>	<input type="checkbox"/>
22: Abandoned Pumping	<input type="checkbox"/>	<input type="checkbox"/>	<input type="checkbox"/>

**Figure 24. THE ALARM CONFIGURATION SCREEN.**

## **OPERATION**

### **NORMAL OPERATION**

During normal operation, the ADH NETCOM automatic air dehydrator begins functioning automatically once power is applied. No operator intervention is required following initial installation and system configuration.

### **INDICATORS**

The ADH NETCOM has two LED indicators, both located on the unit front panel. The Power indicator lights up whenever power is running to the unit. The Alarm indicator functions as a summary alarm and lights up to indicate the presence of any of several alarm or warning conditions. When an Alarm condition is indicated, connect to the system using the Ethernet connection, then look at the Status information. The alarm condition will be displayed there.

### **STATUS INFORMATION**

To obtain operational status information for the ADH NETCOM, use either the simple web interface or query the dehydrator via SNMP. Optionally, the dehydrator may be queried using the S-A protocol via one of the serial ports on the back of the units. Refer to Appendix C.

### **PLACING A DEHYDRATOR IN STAND-BY**

The ADH NETCOM can be switched between online or stand-by mode either through the web interface, by issuing an SNMP command, or by issuing a stand-by command using the S-A Protocol.

## **MAINTENANCE**

### **PREVENTIVE MAINTENANCE**

The ADH NETCOM automatic air dehydrator requires no preventive maintenance. All components are designed for a minimal operational life of 15 years at duty cycles up to 20%. Higher duty cycles may reduce component life.

### **CORRECTIVE MAINTENANCE**

Verifying the performance of the ADH NETCOM requires special equipment, fixtures, and expertise. Please consult with Environmental Technology Customer Service before attempting to service or repair an ADH NETCOM unit.

### **WARNING**

Servicing should be performed by qualified personnel. ADH NETCOM dehydrators contain lethal voltages. Assume that all circuits are live. Attached ADH NETCOM automatic air dehydrators may produce as much as 24 psig (1,655mbar) under worst-case failure. Vent the system to the atmosphere before servicing pneumatic components.

All fittings and hardware are in standard American dimensions, or inches. Use a solution of mild liquid dish detergent and water to locate air leaks. By convention, Drying Canister 1 is the drying canister on the left when viewed from the front of the unit.

### **CAUTION**

Do not apply power to the unit unless all internal connections have been made. Failure to do this may result in component damage.

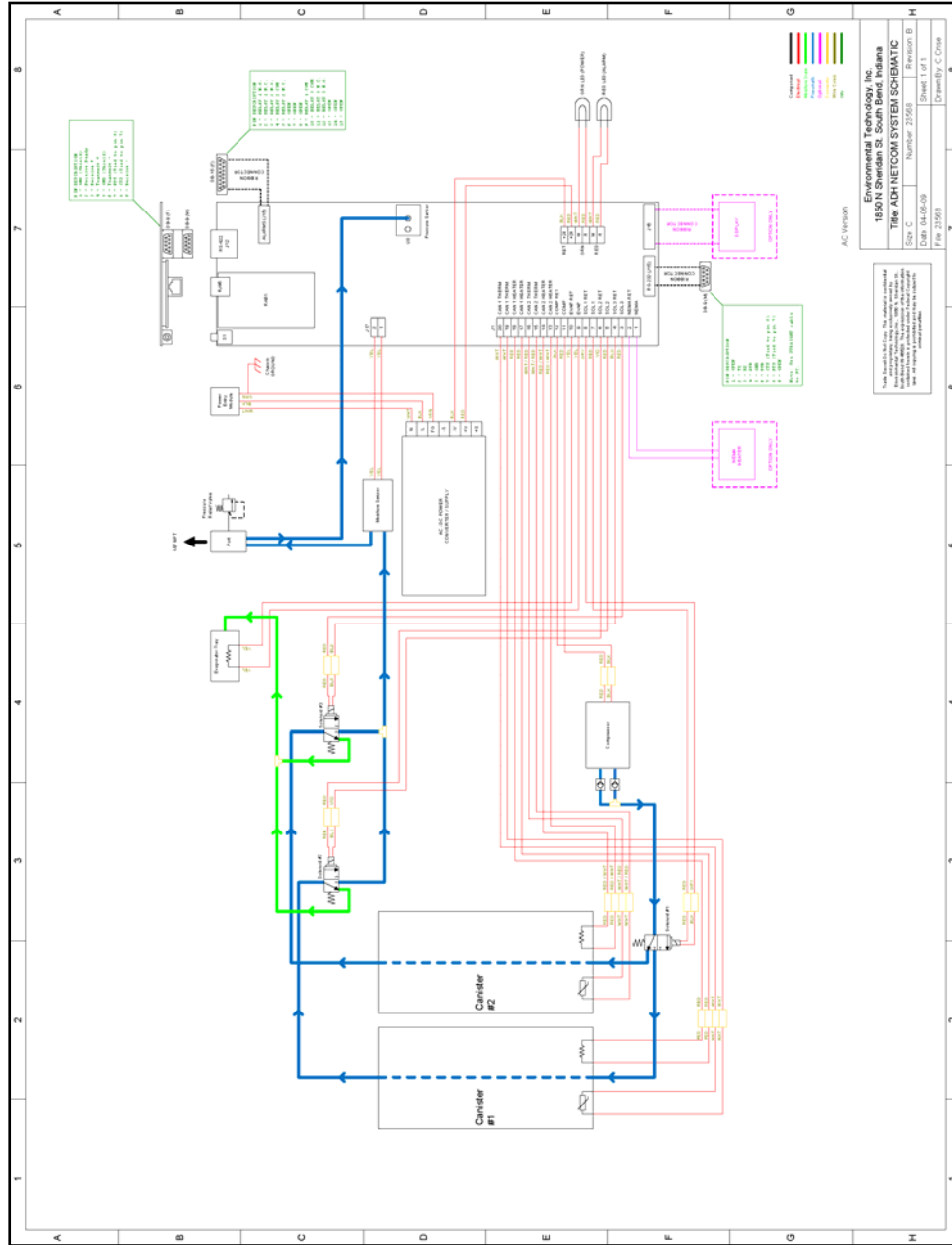
It is best to return the entire unit to Environmental Technology for evaluation and repair, but we realize that is not always possible. If you can determine the problem and its resolution, replacement components can be obtained from Environmental Technology.

## TROUBLESHOOTING

Presented in Table 8 below is a guide for use in Troubleshooting, showing the specific alarm or warning condition with the applicable Troubleshooting Flowchart in this section.

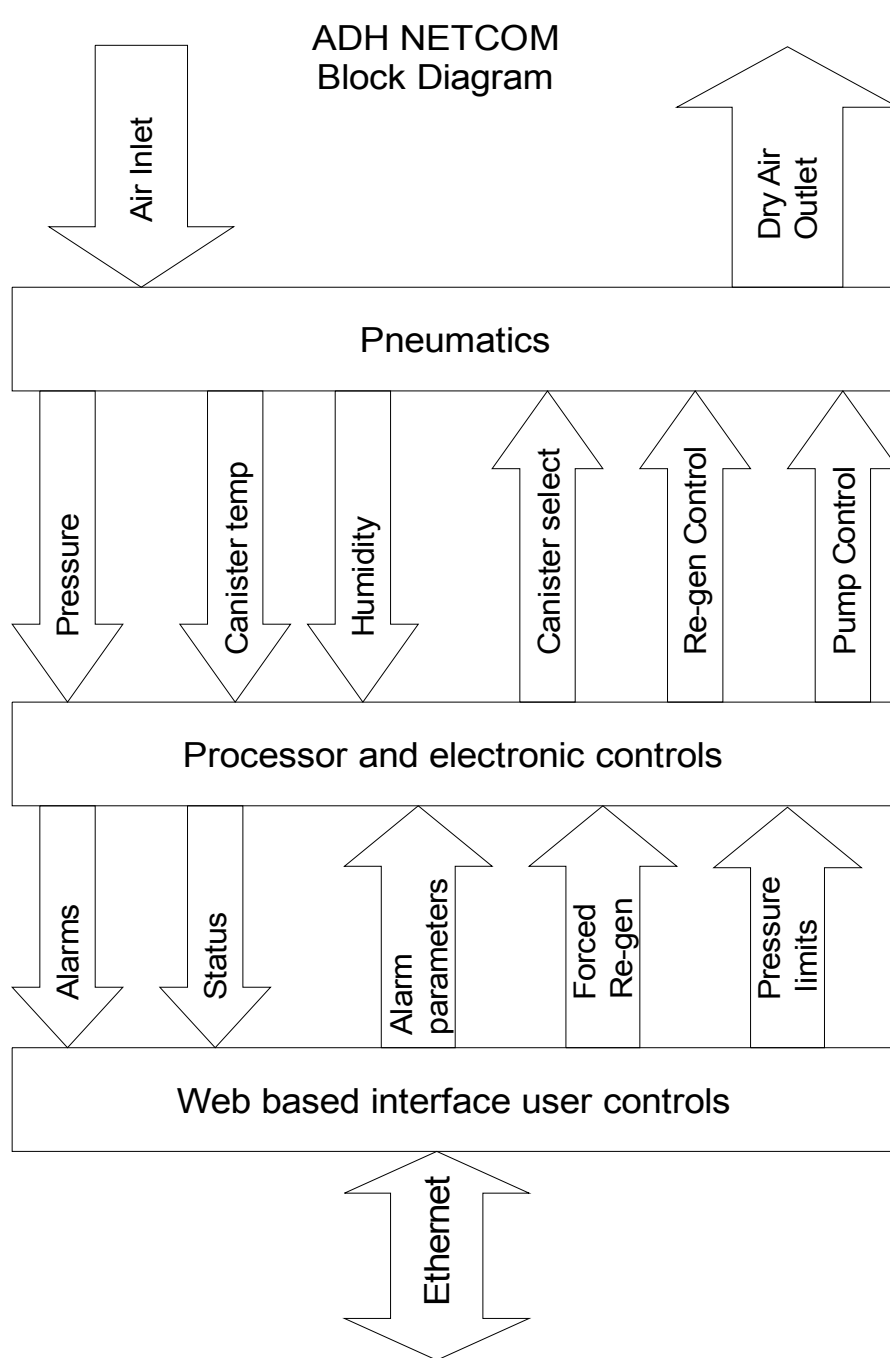
<b>ALARM / WARNING NUMBER</b>	<b>ALARM DEFINITION</b>	<b>FLOWCHART SLIDE</b>
A1	Low Pressure	3
A2	High Pressure	4
W3	High Duty Cycle	3
W4	High Temperature	5
W5	Low Temperature	5
W6	Unused	-
A7	Canister 1 Won't Heat	6
A8	Canister 1 Won't Cool	7
A9	Canister 2 Won't Heat	6
A10	Canister 2 Won't Cool	7
A11	Unable to Pressurize	3
A12	Dew Point Alarm	8
W13	Unused	-
W14	Communications Error (Master units only)	9
A15	Canister 1 Thermistor Bad	6
A16	Canister 2 Thermistor Bad	6
A17	Ambient Thermistor Bad	5
A18	Overpressure	4
A19	Bad Calibrations in EEPROM	11
A20	Bad Limits in EEPROM	11
A21	Short Cycling	12
A22	Pump Shutdown Due To Error Condition	13

**Table 8. TROUBLESHOOTING FLOWCHART GUIDE.**



**Figure 25. ADH NETCOM  
SYSTEM SCHEMATIC DIAGRAM.**

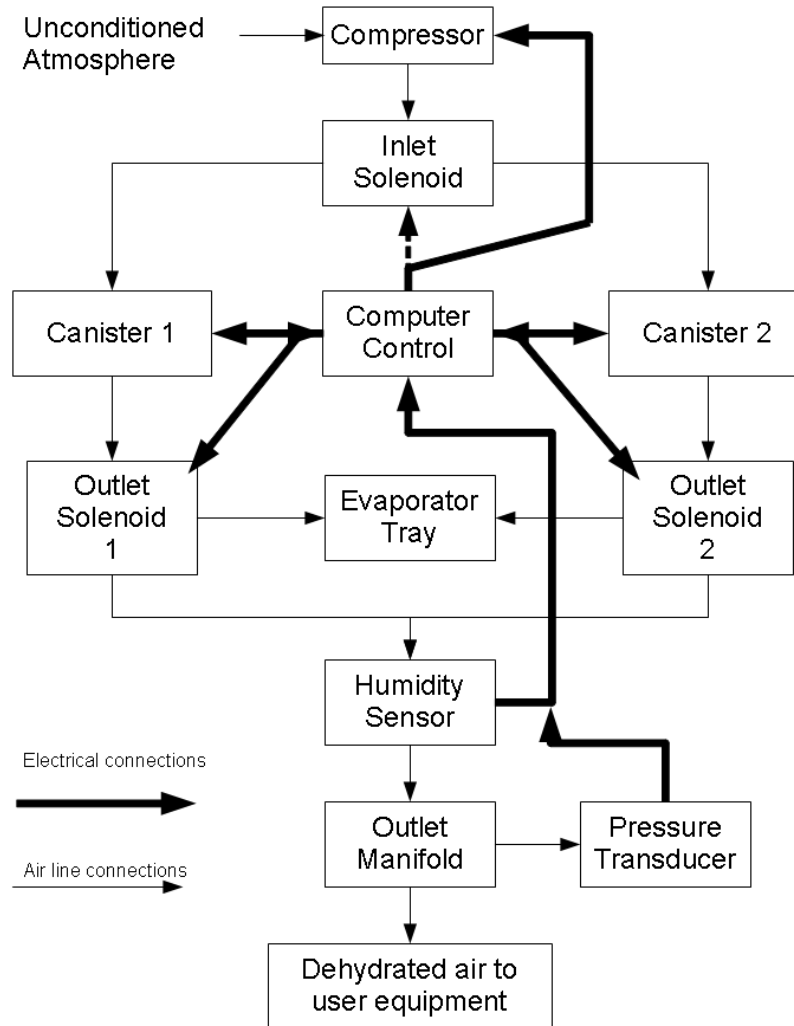
Download available at:  
[www.networketi.com/telecom/adhnetcomflow.html](http://www.networketi.com/telecom/adhnetcomflow.html)



**ADH NETCOM TROUBLESHOOTING FLOWCHART 1.**

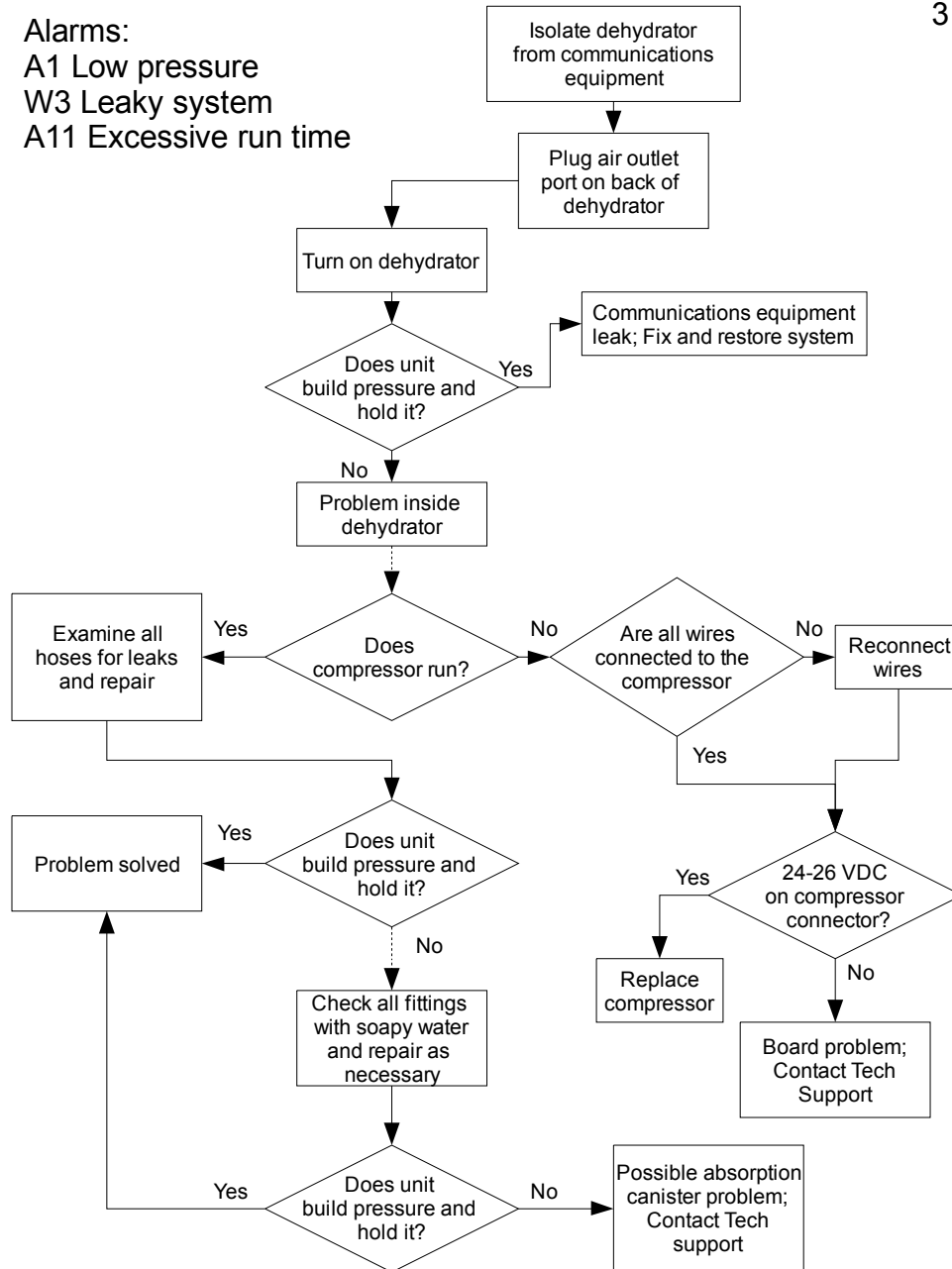
Pneumatics Block Diagram

2



**ADH NETCOM TROUBLESHOOTING FLOWCHART 2.**

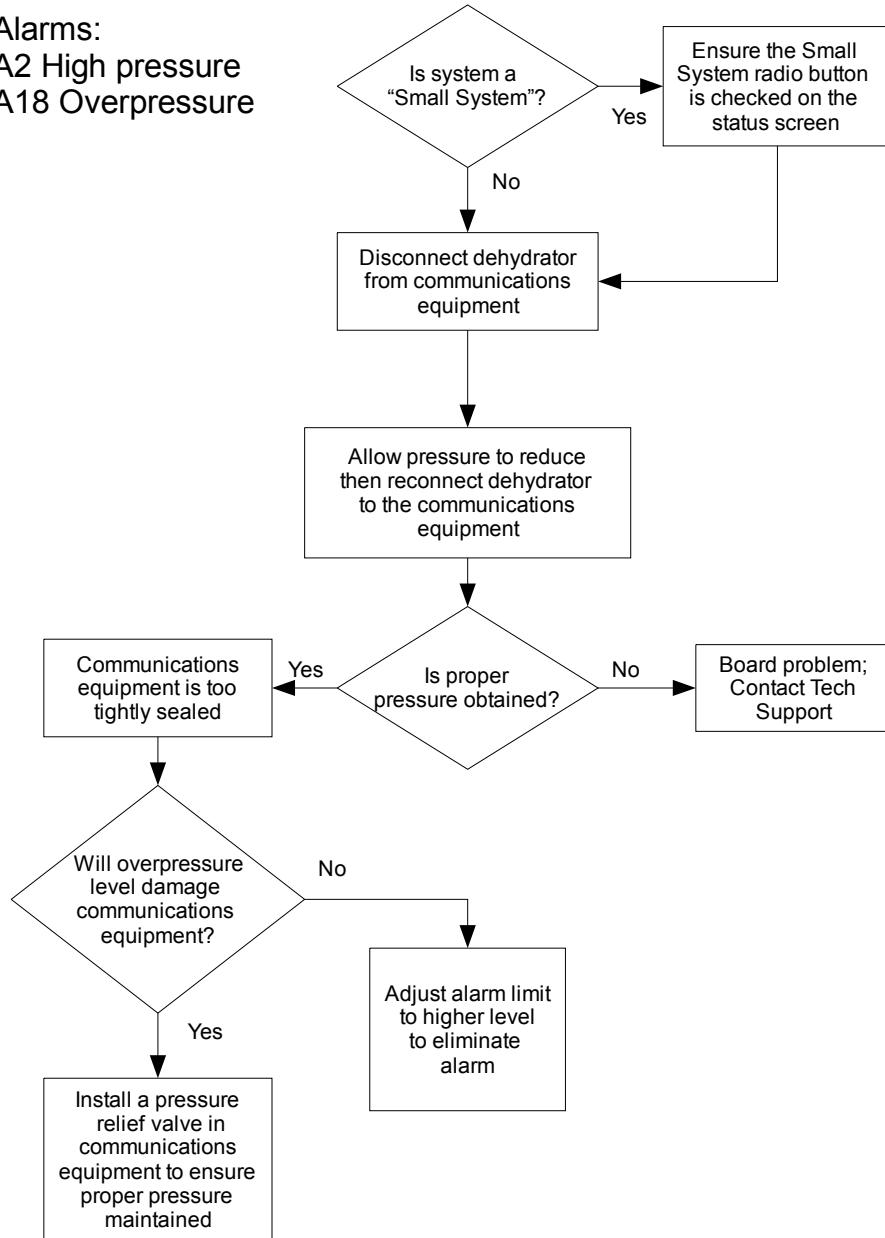
Alarms:  
A1 Low pressure  
W3 Leaky system  
A11 Excessive run time



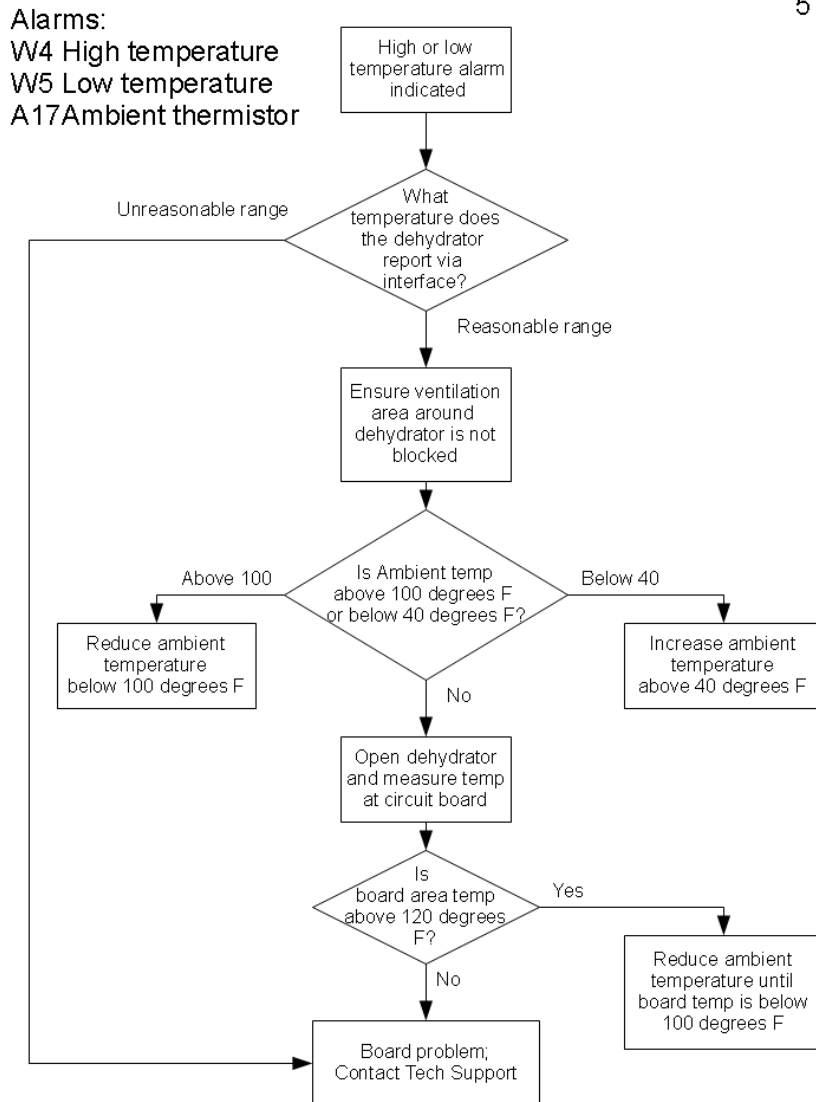
**ADH NETCOM TROUBLESHOOTING FLOWCHART 3.**

4

Alarms:  
A2 High pressure  
A18 Overpressure

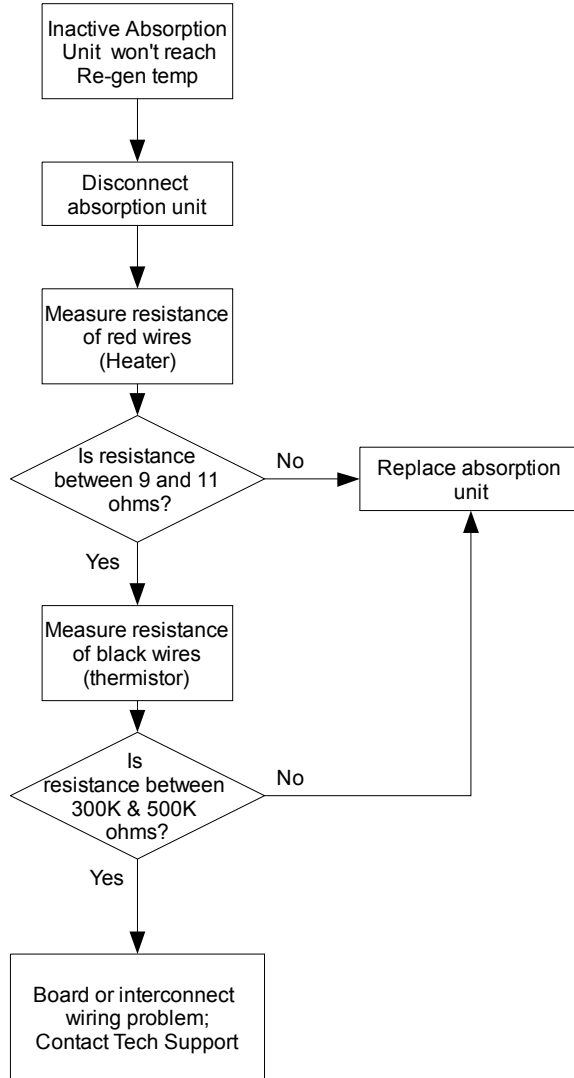


**ADH NETCOM TROUBLESHOOTING FLOWCHART 4.**



**ADH NETCOM TROUBLESHOOTING FLOWCHART 5.**

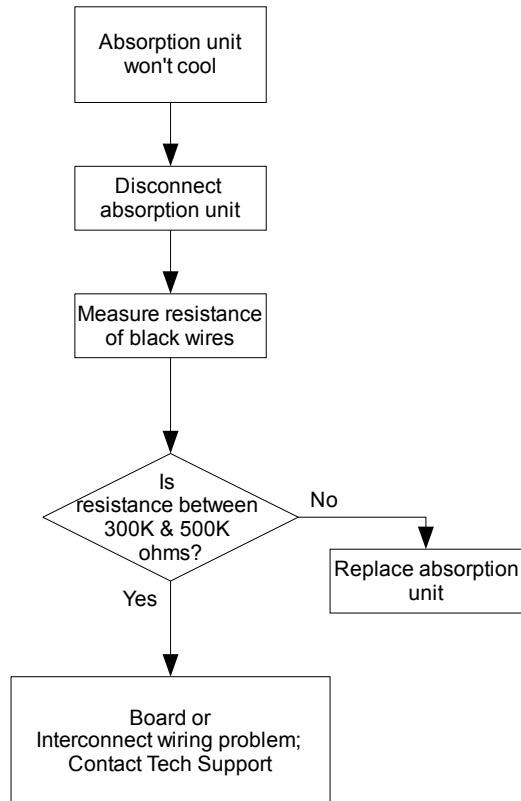
Alarms:  
 A7 Absorption unit 1 won't heat  
 A9 Absorption unit 2 won't heat  
 A15 Thermistor 1 bad  
 A16 Thermistor 2 bad



**ADH NETCOM TROUBLESHOOTING FLOWCHART 6.**

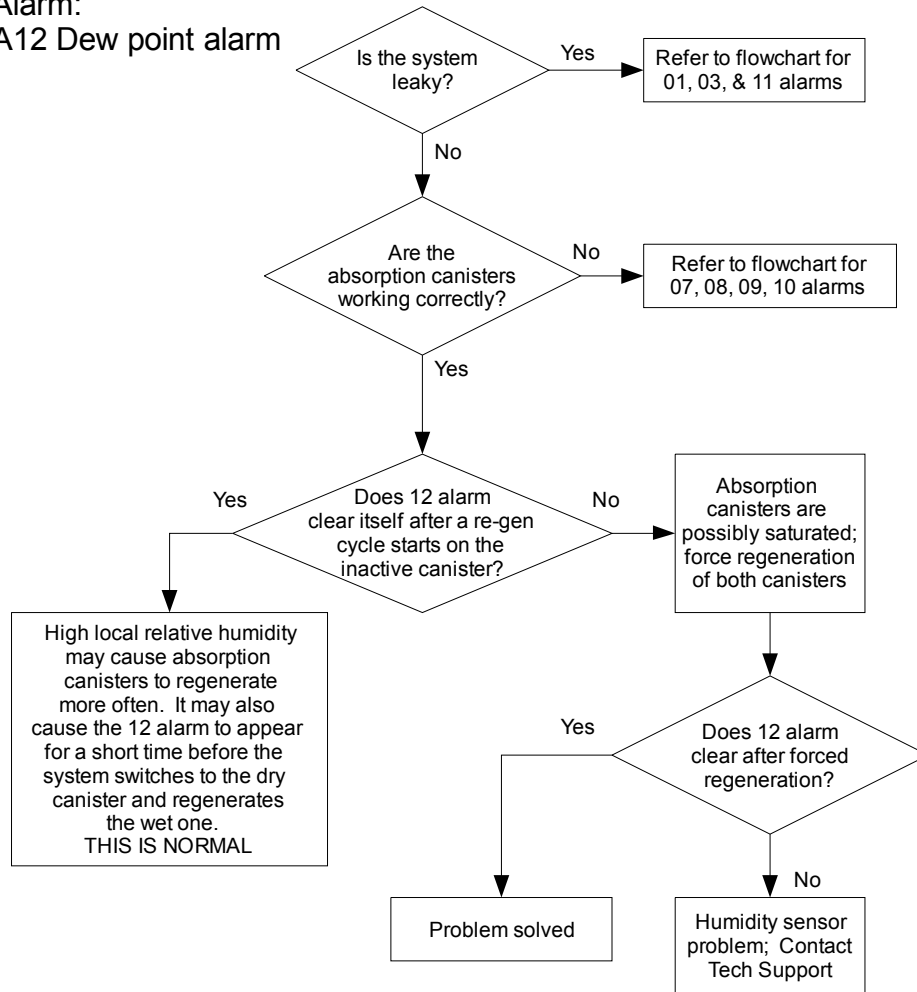
Alarms:  
A8 Absorption unit 1 won't cool  
A10 Absorption unit 2 won't cool

7



**ADH NETCOM TROUBLESHOOTING FLOWCHART 7.**

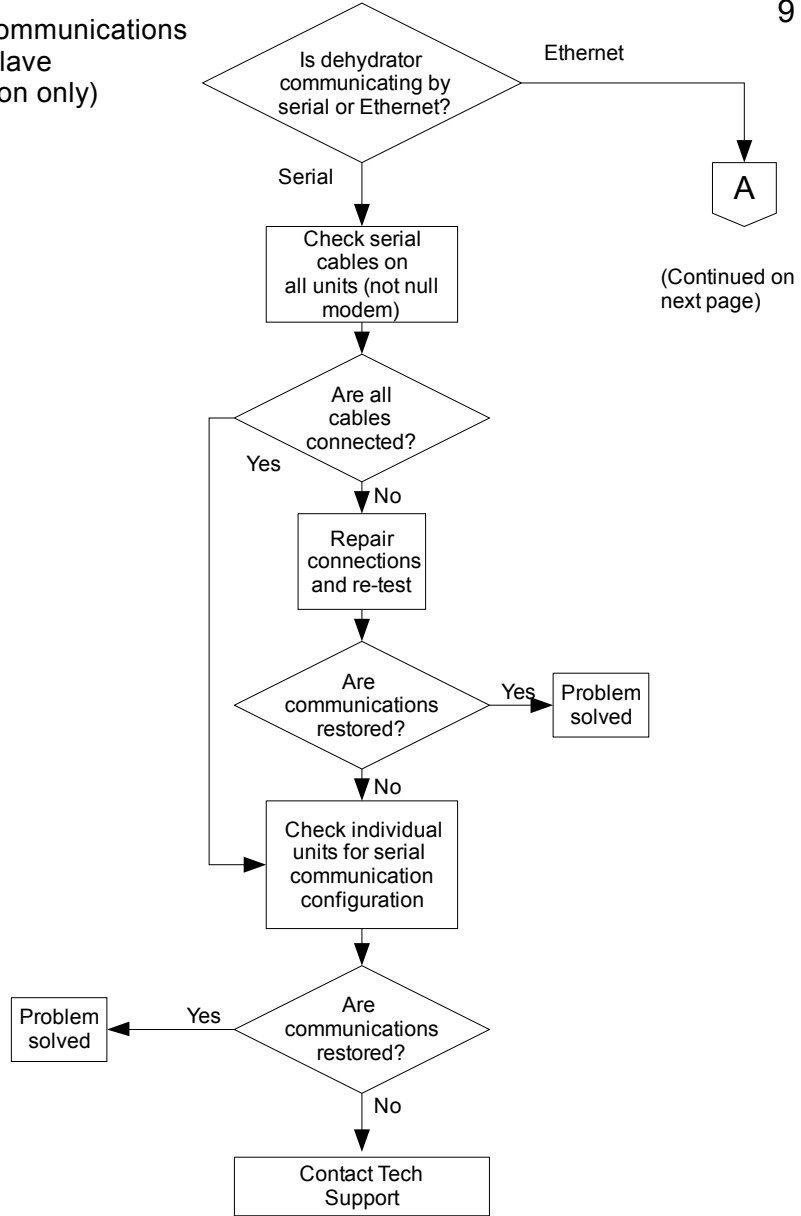
**Alarm:**  
**A12 Dew point alarm**



**ADH NETCOM TROUBLESHOOTING FLOWCHART 8.**

Alarm:  
W14 No Communications  
(Master / slave  
configuration only)

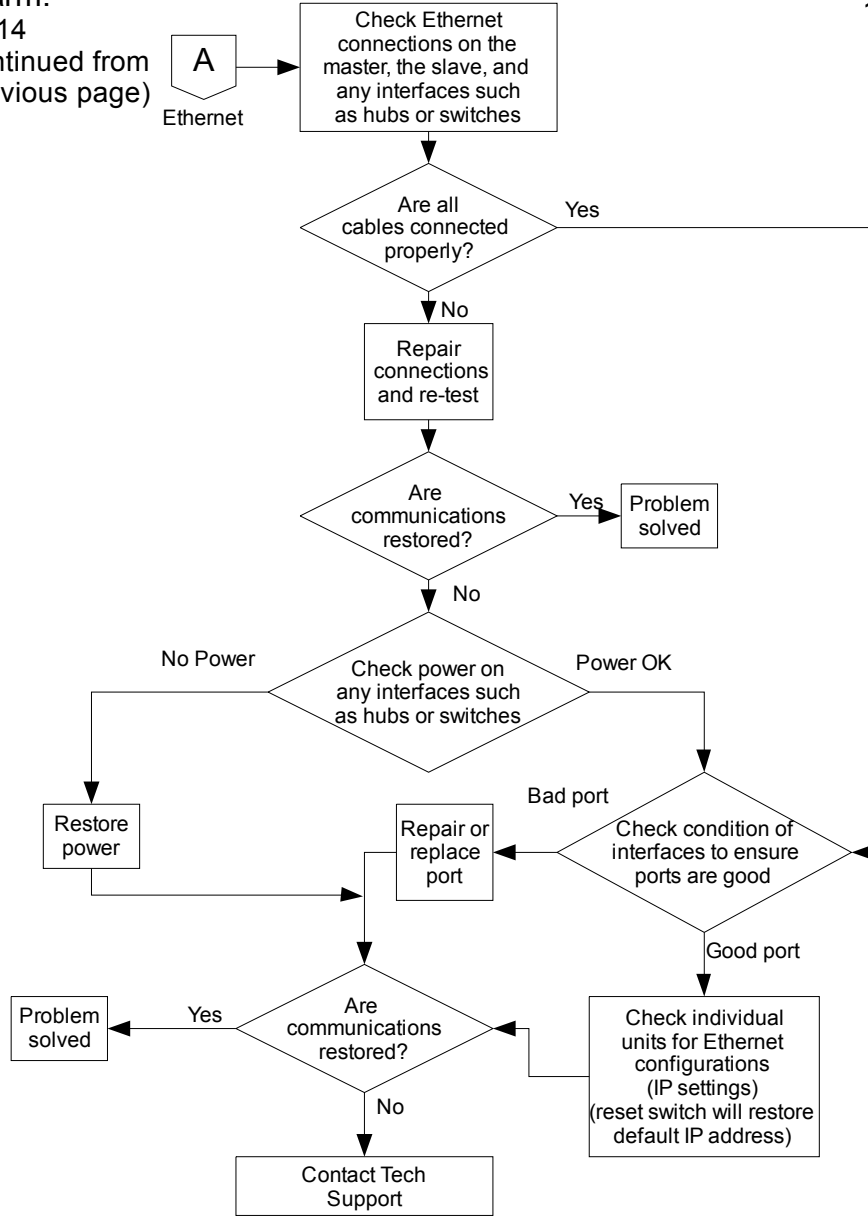
9



**ADH NETCOM TROUBLESHOOTING FLOWCHART 9.**

Alarm:  
(W14  
continued from  
previous page)

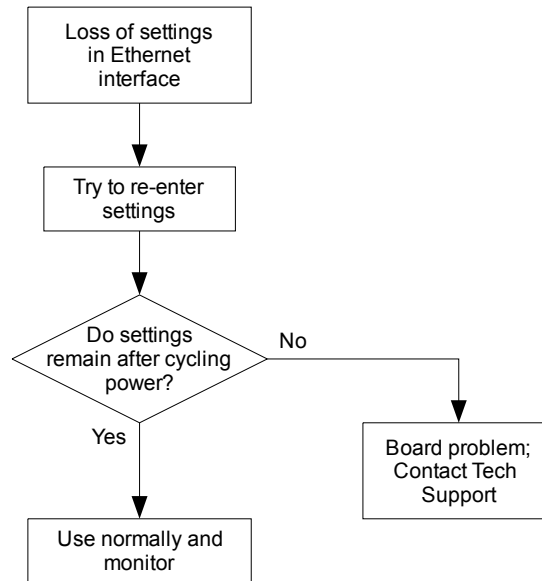
10



**ADH NETCOM TROUBLESHOOTING FLOWCHART 10.**

Alarm:  
A19 Bad Calibrations in EEPROM  
A20 Bad limits in EEPROM

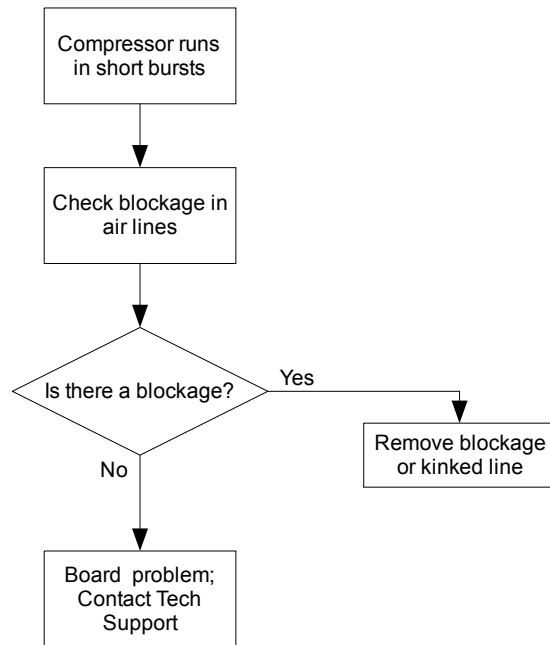
11



**ADH NETCOM TROUBLESHOOTING FLOWCHART 11.**

Alarm:  
A21 Short cycling

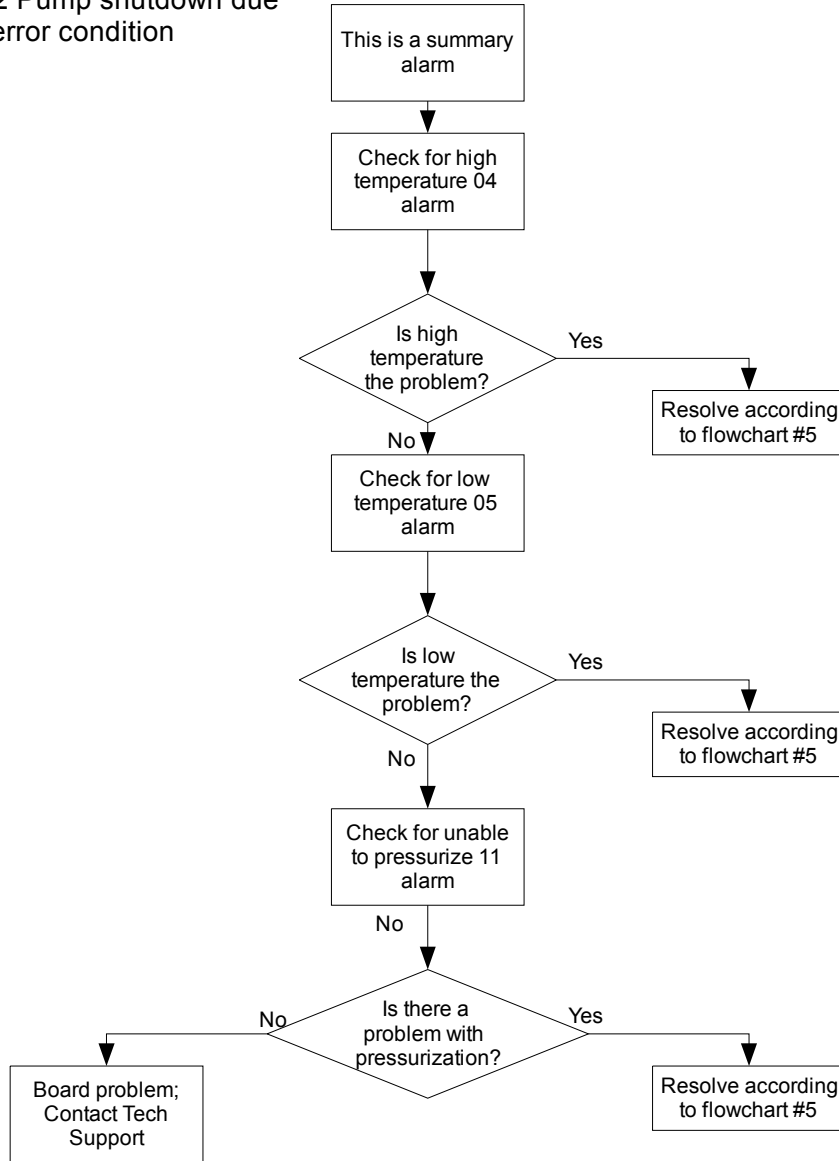
12



**ADH NETCOM TROUBLESHOOTING FLOWCHART 12.**

Alarm:  
A22 Pump shutdown due  
to error condition

13



**ADH NETCOM TROUBLESHOOTING FLOWCHART 13.**

## REPLACEMENT PARTS

Listed below are the part names and numbers which may be used to order replacement parts for the ADH NETCOM automatic air dehydrator. To order parts for the ADH NETCOM or any ETI product, contact ETI Customer Service at (800) 234-4239 or (574) 233-1202 between the hours of 8:00 a.m. and 5:00 p.m., Eastern Time.

<b>PART NUMBER</b>	<b>ITEM DESCRIPTION</b>
23247	Front Panel Assembly
23253	Main Circuit Board
23216	Compressor Assembly
23218	Absorption Unit
23446	Power Module, AC Switched (for 23437*)
23563	Power Filter, RFI (for 23483*)
23173	Discharge Manifold with Safety Relief Valve (for 23437* and 23242*)
23549	Discharge Manifold with Safety Relief Valve (for 23483*)
23269	Solenoid, Right Outlet
24051	Solenoid, Right Outlet (for 23483*)
23214	Solenoid, Left Outlet
23270	Solenoid, Inlet
23368	Humidity Sensor Assembly (for 23437* and 23242*)
23707	Humidity Sensor Assembly (for 23483*)
23219	Evaporator Module
23445	AC Power Supply
23224	DC Power Supply
23526	ADH NETCOM Installation & Operation Manual (this document)
23257	Accessory Kit, ADH NETCOM, AC
23233	Accessory Kit, ADH NETCOM, DC
23572	Accessory Kit, ADH NETCOM, AC NEMA
17618	Power Cord
23245	Mounting Bracket Pair (2)



The Item Descriptions above that refer to numbered units are as follows:

- 23437 - ADH NETCOM, AC Unit
- 23242 - ADH NETCOM, DC Unit
- 23483 - ADH NETCOM, NEMA Unit

## SPECIFICATIONS

Specifications for the ADH NETCOM automatic air dehydrator are listed below. Refer also to the Product Label on the unit itself.

### GENERAL

Approvals	 <p>Type 1950 Information Technology Equipment</p>  <p>Also evaluated by Underwriters Laboratories Inc.<sup>®</sup> In accordance with IEC Publication 60950</p>
-----------	--

### ENCLOSURE

Dimensions	17" × 12" × 5-1/4" (432mm × 305mm × 133mm)
Weight	11 lbs (5 kg)
Mounting	Dual-post rack, flush mounted Single-post rack, center mounted Wall mounted

### POWER

	AC MODEL	DC MODEL
Supply	100-240 VAC, 50/60 Hz	±20-75 VDC
Maximum Current	1.0 Amps at 100 V	5 Amps at 20 VDC
Power Usage	100 W maximum	100 W maximum
Heat Dissipation	205 BTU/hr max.	205 BTU/hour maximum

### OUTPUT

Maximum Pressure	7.5 psig (517mbar)
Operating Units	SI (millibars); English (psig), default

## CONTROL

Protocols	HTTP (Web Interface), SNMP, UDP, TFTP
Maximum Pressure	Configurable Range: 0.20 psig to 7.5 psig (14mbar to 517mbar), Default: 0.50 psig (34.5mbar)
Minimum Pressure	Configurable Range: 0.10 psig to 7.4 psig (7mbar - 510mbar), Default: 0.30 psig (21mbar)
Low Pressure Alarm Level	User-Configurable, Default: 0.15 psig (10mbar)
High Pressure Alarm Level	User-Configurable, Default 1.5 psig (103.5mbar)
Alarm Relays	Contact Type - Form C, SPDT, reverse acting Ratings - 0.25 Amps @ 60 V User-Configurable, Defaults: Alarm Relay 1: Summary Alarm Alarm Relay 2: Low Pressure Alarm Alarm Relay 3: Dew Point Alarm

## ENVIRONMENTAL

Operating Temperature	32°F to 130°F (0°C to 55°C)
Storage Temperature	-40°F to 150°F (-40°C to 60°C)

## **APPENDIX A – ADH NETCOM NEMA CONFIGURATION**

### DESCRIPTION

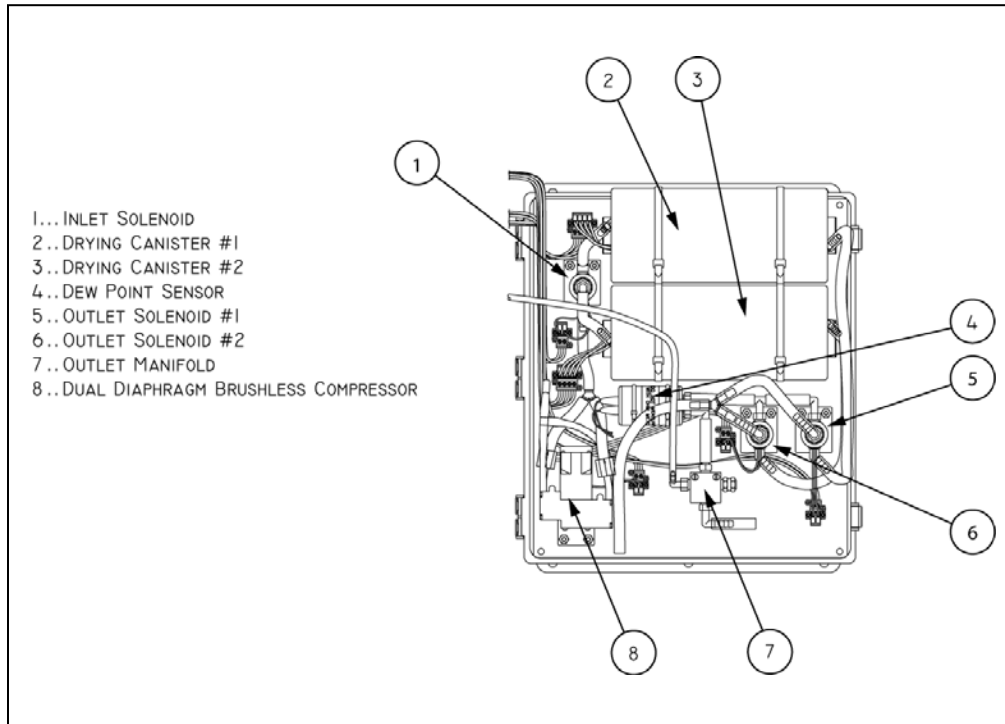
The ADH NETCOM NEMA automatic air dehydrator provides the same functionality as the standard ADH NETCOM automatic air dehydrator, housed in an environmentally sheltered polypropylene, IP66, NEMA 4X enclosure. Because of the NEMA enclosure, the unit can be mounted outside which not only saves interior shelf space but also protects the unit from harmful environmental factors. While the NEMA enclosure keeps out moisture, the temperature control system allows operation down to -40°F (-40°C). Refer to Figures 1 and 2 below for views of internal components and dimensions.

Power requirements for the standard and NEMA units are the same: 100 to 240 VAC or +/-20 to 75 VDC, 50 / 60 Hz, and 1.5 Amps at 100V. Each voltage range is auto-sensing and requires no special configuration. The temperature control system in the NEMA unit allows reliable operation from -40°F (-40°C) to 130°F (55°C), with a storage temperature range from -40°F (-40°C) to 150°F (60°C).

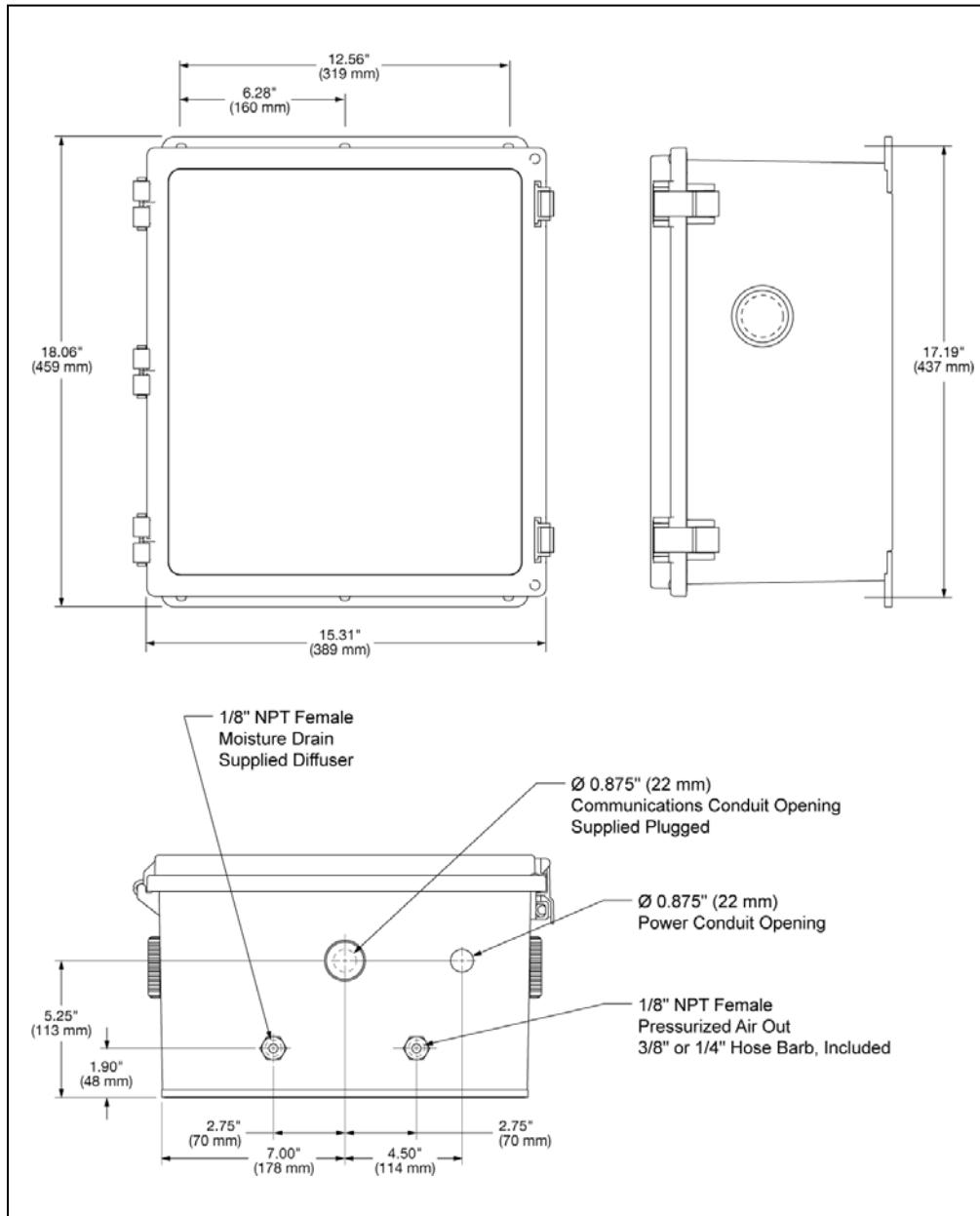
Communications features are the same for the standard ADH NETCOM as for the NEMA configuration. Specifically, the following computer communications protocols can be used:

- Hypertext Transfer Protocol (HTTP);
- Simple Network Management Protocol (SNMP);
- User Datagram Protocol (UDP); and
- Trivial File Transfer Protocol (TFTP).

The NEMA enclosure has a dedicated temperature and humidity control system to enable outdoor operation. To save energy, small heaters are mounted near the pump to allow normal operation at temperatures below 40°F, while excess heat from those heaters is utilized within the enclosure to heat other, less temperature sensitive components. To keep moisture from collecting internally, pressurized water vapor is discharged from the dehydrator through a discharge port and diffuser during regeneration. The ADH NETCOM NEMA automatic air dehydrator is also available with optional Type 1 and Type 2 MIL-SPEC connectors, making field replacement quick with minimal downtime.



**Figure 1. ADH NETCOM NEMA COMPONENTS.**

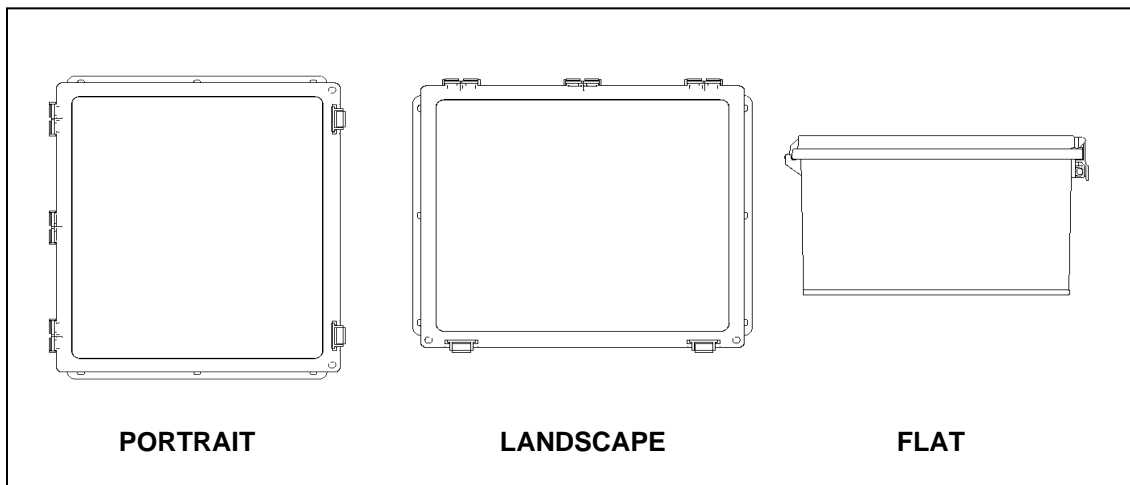


**Figure 2. ADH NETCOM NEMA DIMENSIONS.**

## PREPARING FOR INSTALLATION

Prior to installing the unit, note the following information to assist in proper placement and installation. We recommend that you read these installation guidelines completely prior to beginning actual installation.

The ADH NETCOM NEMA automatic air dehydrator can be installed on a post or pole, on a shelf, or on a wall. Due to size and space constraints, do not mount the ADH NETCOM NEMA in a rack. The enclosure can be oriented with the hinges on the left side of the box (portrait), along the top of the box (landscape), or with the enclosure feet down (flat). See Figure 3.



**Figure 3. THE ADH NETCOM NEMA  
IN ITS THREE MOUNTING OPTIONS.**

To install the unit vertically, a suitable mounting area measuring 24" W x 26" L x 10" D (610mm W x 660mm L x 250mm D) must be available. The mounting hardware and the wall chosen for the installation should be capable of supporting a static load about four times the weight of the unit, or 100 pounds (45kg).

The ADH NETCOM NEMA automatic air dehydrator is permanently connected equipment and does not have an internal disconnect device. A readily accessible disconnect device, short circuit, and current protection shall be provided by the customer and are not supplied by Environmental Technology, Inc. If the unit is part of a building installation or may be subject to transient overvoltages exceeding those for International Electrical Code (IEC) Overvoltage Category II, then the customer shall also provide additional protection to satisfy IEC Overvoltage Category III and IV.

AC power shall be provided with protection that complies with UL 1449 and IEC 61643. A branch circuit with a 15A breaker for short circuit protection is required. When not using the optional Type 1 or Type 2 military connector kits, the power terminal block is suitable only with 14 AWG copper wire. A 7/8" hole is provided at the bottom of the enclosure for a conduit connection for the electrical wiring.

The customer is responsible for installing the unit in a secure, Restricted Access Location, accessible only by personnel qualified to work with this equipment.

The installation instructions presented here are divided into two sections: basic installation, followed by installation of communications cables. Basic installation presents the information necessary to get the unit installed, connected, and functioning properly. The second section addressing advanced communications installation details the installation of the communications cable(s) necessary to enable the various optional computer communications capabilities for the unit. Remember that it will be necessary to access the inside of the enclosure following basic installation in order to install the desired communications cables.

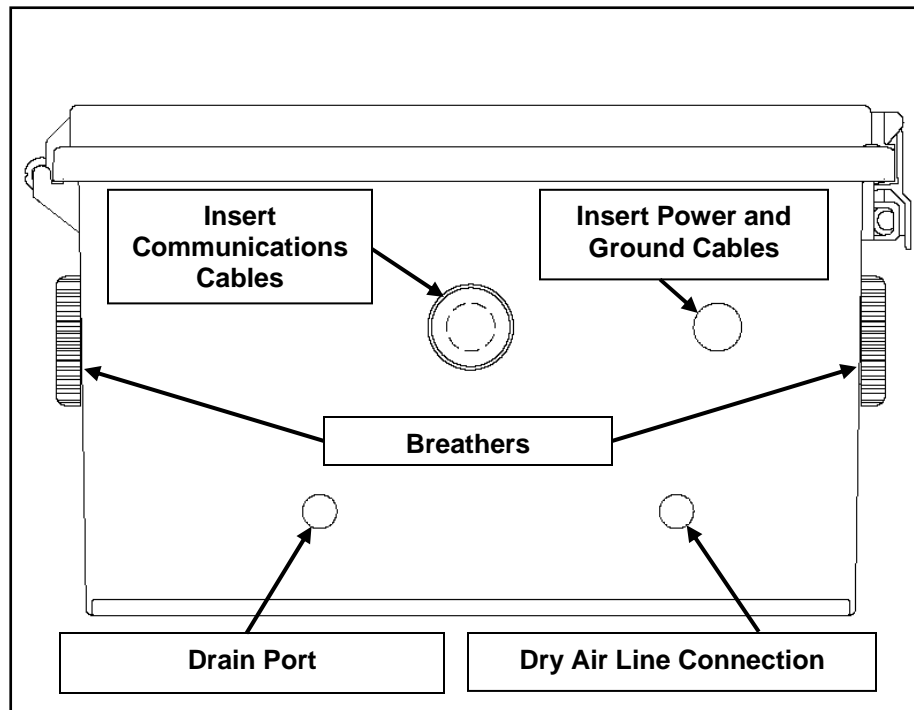
## BASIC INSTALLATION

To install the ADH NETCOM NEMA automatic air dehydrator, perform the steps below.

### NOTE

The ADH NETCOM NEMA automatic air dehydrator does not have a Power Switch. For that reason, remember that power is running to the unit as soon as the power source cable is connected. At this time, shut off the facility circuit breaker serving the ADH NETCOM NEMA.

1. Before proceeding with installation, make sure the facility circuit breaker serving the ADH NETCOM NEMA unit has been shut off.
2. Using four 5/16" mounting bolts, fasten the unit to the supporting wall or surface. To ensure stable mounting, use mounting hardware of a length appropriate to the surface or material on or into which the unit is being installed. The ADH NETCOM NEMA automatic air dehydrator unit weighs 24 lbs (10.9 kg). The installation surface or material must be capable of supporting a static load of approximately four times the weight of the unit, or 100 pounds (45kg). Fasten mounting hardware securely.
3. At this time, make the drain port connection. For this step, there are two options, as desired, depending on the installation location and function. Refer to Figure 4. Either carefully connect the bronze muffler to the fitting on the drain port (to serve as a moisture diffuser), or connect an 1/8" NPT male end barbed hose fitting to the drain port fitting, attach a hose, then route the hose to a facility drain.

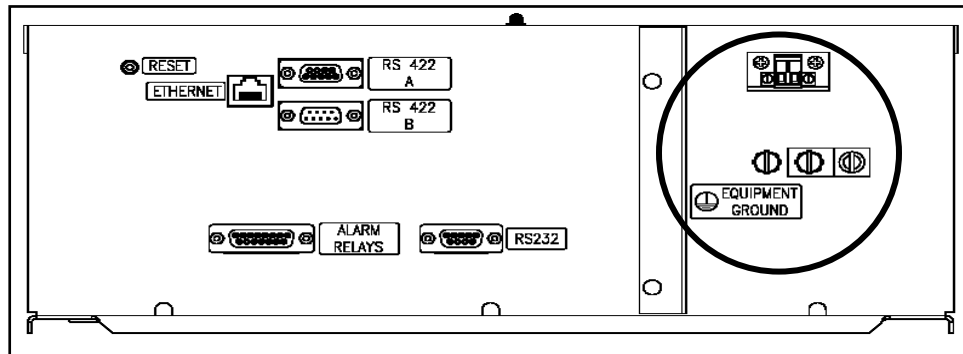


**Figure 4. BOTTOM OF NEMA ENCLOSURE.**

### **NOTE**

If using the bronze muffler, do not force it into place as doing so might strip the threads. If the muffler does not screw onto the drain port fitting easily, carefully unscrew it, reseal it, try screwing it in again. If using a hose connected to the drain port fitting, make sure the hose points down. The unit design prevents freezing inside the enclosure. It is the customer's responsibility to ensure that the added hose line does not freeze outside the enclosure. Finally, if using a hose, install a small filter or screen at the end of the hose to help keep bugs from getting up inside the hose.

4. Connect and secure the dry air supply line to the 1/8" NPT female connection at the bottom of the unit using the appropriate fitting.
5. To install the power and ground wires, run the power and ground cables inside conduit through the 7/8" access hole in the bottom of the enclosure to the inside of the enclosure. The 7/8" hole will accommodate 1/2" conduit. Leave enough slack to extend the cables to their respective terminal lugs. Remove enough of the insulation at the end of the wire or cable to be able to make the connection into their respective terminal lugs.
6. At this time, connect the power and ground wires to their respective terminal lugs inside the enclosure. Refer to Figure 5. Once the power and ground wires have been connected securely inside the enclosure, seal the access hole so that no ambient air can get inside the enclosure. If desired, first seal the hole and then connect the wires.



**Figure 5. ADH NETCOM NEMA POWER CONNECTIONS.**

7. Two breathers are located on the enclosure, one on either side, as shown back in Figure 4 in this appendix. They allow air into the enclosure. Do not remove the breather caps. They are specially designed to let air into the enclosure, while preventing water and dust entry. Turn the breather caps clockwise at this time just to make sure they are properly seated.

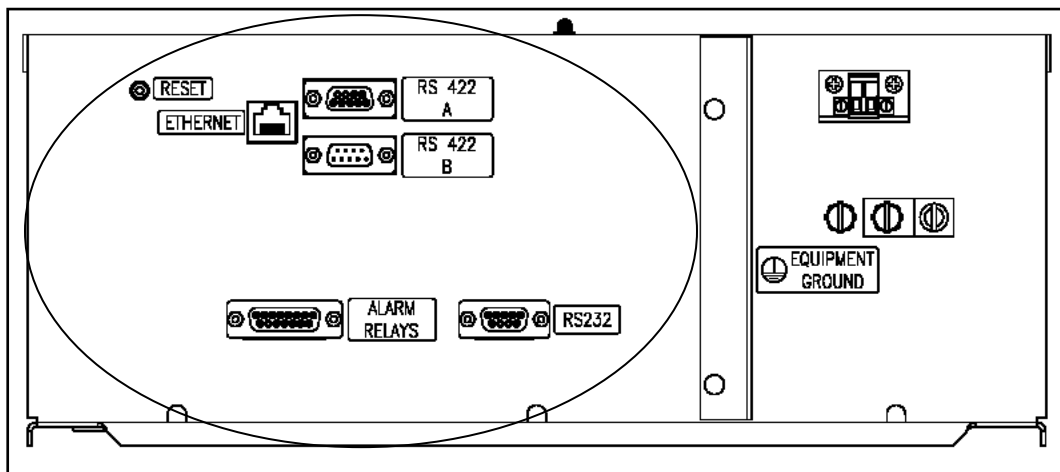
#### INSTALLING THE OPTIONAL COMMUNICATIONS CABLES

With the enclosure installed and the two breathers tightened, the filter or hose connected to the drain port, the power and ground wires connected, and the enclosure power and ground cable access hole sealed, the unit is now ready for operation. However, to take full advantage of the ADH NETCOM NEMA automatic air dehydrator communications capabilities, it is advised to connect, as desired, the communications cables as described below. Although the unit can now function, it cannot alert the user to any of the alarm conditions which the unit has been designed to report, nor can any reconfiguring of the unit be done remotely, without the communications cable(s) installed.

To facilitate communications with the ADH NETCOM NEMA automatic air dehydrator, three (3) serial ports, three (3) alarm relays, and an Ethernet port have been provided. Most often, when replacing an old unit, the RS-422/485 cable will be used. When installing a new unit that is not replacing an existing unit, the use of the Ethernet cable is recommended for monitoring unit status.

There are two ports for the RS-422/485 cable, labeled A and B, as well as a port labeled for the RS-232 cable. Of the two RS-422/485 ports, A is the female end, while B is the male end. Be careful when installing these cables because the female (port A) connector end of the RS-422/485 cable is the same as the connector end of the RS-232 cable. For a description of pin assignments for the RS-422/485 cable, refer back to Figure 18 in the main body of this Manual. See Figure 19 in the Manual for alarm relay connector pin assignments.

8. To install the communications cables, begin by unscrewing the plug cap from the bottom of the enclosure covering the weather-tight gray connector port. Separate the two halves of the plug cap by unscrewing them from each other from the inside of the enclosure. Once removed, both halves of the plug cap can be discarded. Run conduit through the access hole, then feed the cables through into the enclosure. The hole in the cap can accommodate the width of a conduit. Feed in enough cable to leave some slack for them to reach their respective ports.
9. Once the communications cables have been fed into the enclosure, connect the cables to their respective ports inside the enclosure. Refer to the labels on the enclosure, as well as to the internal interconnect diagrams for more detailed information. Refer to Figure 6. As in step 6, seal the communications cable access hole so that no ambient air can get into the enclosure. If desired, seal the hole first, then connect the wires.



**Figure 6. ADH NETCOM NEMA COMMUNICATIONS CONNECTIONS.**

10. Once all cable connections are made and the unit is properly sealed, close and secure the enclosure using the fastening latches. Make sure the latches snap into position to make sure they are fully closed and secured.
11. Finally, once installation is complete, turn the facility circuit breaker back on and verify that the installation was successful. The unit will make a vibrating sound when the pump is operating.

### CONFIGURING THE UNIT

Now that the unit is installed and connected successfully, it will be necessary to configure or set up the specific values and performance parameters desired for your specific unit, installation, or location. Refer back to the section entitled Configuring, located on page 22 in the main body of this Manual.

Once the newly installed unit has been successfully configured, verify that the system pressurizes and is running a duty cycle less than 20%.

## **APPENDIX B – COMMUNICATION PROTOCOLS**

### **OVERVIEW**

On an Ethernet network, the ADH NETCOM automatic air dehydrator primarily uses the UDP network protocol for communication between an ADH NETCOM automatic dehydrator and one or more other ADH NETCOM automatic air dehydrator units. UDP is also the protocol that will be used to communicate between an ADH NETCOM unit and an ASM-1 Smart Manifold. M&C systems may also use UDP, along with or instead of SNMP.

The ADH NETCOM has three configurable serial communication ports: an RS-422/485 male port, an RS-422/485 female port, and an RS-232 female port. Each port communicates at 9600 baud by default, but may be configured as a “slow” port and communicate at 1200 baud. Only the RS-422/485 female port can be configured to use pull-ups or not. The RS-422/485 male port always has pull-ups.

Devices intended to communicate with an ADH NETCOM using one of its three serial ports must be configured to use a baud rate the same as that of the port to which it is connected. Additionally, the connecting device needs to be configured for seven data bits, one stop bit, and even parity.

### **SERIAL COMMUNICATIONS**

The ADH NETCOM air automatic dehydrator provides serial communications for directly connecting one dehydrator to another or for compatibility with legacy M&C systems. There are four configurable modes of operation: Standard mode, Terminal mode, Master mode, and Unused. Standard mode complies with the Scientific-Atlanta (S-A) protocol. In terminal mode, the unit responds in straight ASCII. Terminal mode should be used when the unit is accessed by a dumb terminal. Master mode allows a port to be used to set an ADH NETCOM as the controlling dehydrator for a standard mode dehydrator. The Standard mode dehydrator (or slave) can be another ADH NETCOM, an ADH-2A COM, or an ADH-3COM. If a port is not going to be used, configure it as Unused.



## Standard Mode Command Format

A valid command in the standard mode must consist of the following: The first character is STX (2 Hex) and is followed by the remote address. Next, the command you wish to execute and the associated data bytes are transmitted. ETX (3 Hex), and the checksum are then sent to conclude the transmission.

## STANDARD MODE RESPONSE TO A COMMAND

The response format of the unit is identical to the command format, except for the first character. If the command was understood, an ACK (06 Hex) will replace the STX character. If the command was not understood or cannot be acted upon, the response will begin with an NAK (15 Hex) and the data bytes will not be returned. Only the NAK, address, command, ETX, and the checksum will be sent.

## CHECKSUM CALCULATION

The checksum is a bitwise exclusive - or of all the characters in the stream. This includes the STX and the ETX characters.

## TERMINAL MODE COMMAND FORMAT

When the unit is placed in Terminal mode, the only valid command is the carriage return (0D Hex). This requests the unit for the status.

## TERMINAL MODE RESPONSE FORMAT

Terminal mode is straight ASCII. The end of line delimiters can be configured as a carriage return (CR), a line feed (LF) or as both.

## USER DATAGRAM PROTOCOL

The ADH NETCOM automatic dehydrator uses the User Datagram Protocol (UDP) network protocol for communicating with one ADH NETCOM automatic air dehydrator and any of the following:

- another ADH NETCOM automatic dehydrator;
- an ASM–1 Smart Manifold; or
- M&C (Monitor and Control) systems.

The ADH NETCOM automatic dehydrator receives commands on UDP port 52091.

When operating as a master dehydrator in master/slave configuration, the master will send out messages using UDP port 52092 as the source port and 52091 as the destination port. In addition, when resolving dehydrator names to an IP address, the ADH NETCOM master will use NetBIOS Name Service (NBNS) on UDP port 52090.

## MESSAGE FORMAT

### S-A Protocol

An S-A protocol query to an ADH NETCOM will consist of the following:

- STX: 02 hex
- S-A Address: configurable to a hex value from 30 to 6f
- Command Character: See list of commands
- Message Data: Zero or more data bytes
- ETX: 03 hex
- Checksum: Exclusive-or of all the other bytes in the message including the control bytes.

The response to a message is in the same form as above, except that the STX is replaced with either an ACK (06 hex) if the message is accepted or a NAK (15 hex) if the message is rejected. The address and command characters of the response must always match the address and command characters of the command. The sender of the command does not have a relevant S-A address.

## UDP Protocol

A UDP message to an ADH NETCOM consists of the following:

- C: 43 hex; C stands for command
- Index: a one-byte field used to match a query to a response
- Command Character: See list of commands
- Zero or more data bytes

The response to a message is in the same form as above, except that the first character is replaced with a return code. The return code will be one of the following:

- Y: Command accepted and acted upon if relevant
- N: Command rejected
- ?: Command not valid

## Commands

Command characters are referred to either as a quoted character (using single quotes) or as that character's hex value. For example, if I want to know the model of automatic dehydrator I am talking to, I would use either '0' or 30 hex as the command character.

## Command Group I

These commands were documented with the ADH-2A COM and ADH-3COM automatic air dehydrators.

'0' – 30 hex – Returns a 6-character ID string. This string is always "NETCOM" for ADH NETCOM automatic air dehydrators. An ADH-3COM may return ADH331, indicating that the ADH-3COM is using software version 3.1.

'1' – 31 hex – Returns a status string.

Note: In the communications set-up screen, the user can choose between English and metric, as well as one of three pressure ranges. The ONLY use of those settings is in the form of the return for the '1' command.

'7' – 37 hex – Go into stand-by. For master/slave configurations, this command will put the master/slave set into stand-by.

'8' – 38 hex – Go online. For master/slave configurations, this command will put the master/slave set online. The specific automatic air dehydrator which will actually be placed online is still controlled by the master.

## Command Group II

Though these commands were not documented with the ADH-2A COM and ADH-3COM automatic air dehydrators, they were used in the master/slave interface.

'2' – 32 hex – Returns a special character call qstat1. See the notes below.

'5' – 35 hex – The same as '2', but sets the communications error flag in the slave.

'J' – 4a hex – Puts the slave into remote mode.

'[' – 5b hex – Sets a flag to turn on the slave compressor if in remote mode.

']' – 5d hex – Sets a flag to turn off the slave compressor if in remote mode.

Notes on this group:

The command '2' returns what we call qstat1: it is a single character encoding important elements of the dehydrator's status.

The low bit (bit 0, binary 1) is set if the unit is "reluctant": this means that it is capable of pressurizing, but would have to use a canister which is or may be wet to do so. We avoid giving control to the slave when it is reluctant, if it is possible to do so.

The second bit (bit 1, binary 2) is set if the unit is currently pressurizing - i.e., the pump is running and aimed at the antenna (although there may be a brief lag of up to 100msec).

The rest of the byte is 'A' (40 hex) plus a state index multiplied by 4. The state index is:

0: On line

1: Stand-by

2: Leaky (Stopped pumping because of a declared leak)

3: Remote (Compressor on or off, according to commands from master)

4: Alternating (Not used, included for legacy compatibility.)

5: Joint (The master's state during parallel pumping.) (Not yet implemented.)

The reason for the '5' command is that it is possible that communications from the master to the slave may be intact but that the return path from the slave to the master could be broken. In that case, the master will not know the slave's status, and will continually broadcast commands to determine it. The slave receives all these commands normally. Without the '5' command, the slave would not declare a communications error and would stay in stand-by forever.

### Command Group III: Commands new to the ADH NETCOM

'9' – 39 hex – The NETCOM returns a string whose first character is 'N', identifying it as a NETCOM. This is mainly to allow the NETCOM to determine whether a slave is a NETCOM or a legacy (earlier) dehydrator. Though this may change in the future, at the time of this writing, the string is 'N2'.

'E' – 45 hex – Returns current status, in English units.

'M' – 4d hex – Returns current status, in metric units. See the next section.

Note: this is a fixed-length string, giving the most important information about the status of the NETCOM.

'L' – 4c hex – Alarms, form 1. This is a fixed-length string, with the Nth character being a '+' if alarm N is set, or a '-' if it is not. The length is 22 characters.

'R' – 52 hex – Alarms, form 2. This is a variable-length string, with two characters for each alarm which is present, giving the number of the alarm (the first character is '0' if the alarm number is less than 10).

'T' – 54 hex – Compressor run time. Return is a variable-length string: a number with one decimal place (the decimal point is included in the string: as "12.3"). This represents approximate accumulated compressor time, in hours.

'C' – 43 hex – Configuration information. The result is a fixed-length string of the form "Xaaabbbccddd". This gives the current pressure limits. If the first letter is E or e, the limits are given in hundredths of a PSI. If the first letter is M or m, the limits are given in mbar. A lower case letter means that it is configured as a small system. The aaa is the lower pressure alarm, the bbb is the lower limit, the ccc is the upper limit, and the ddd is the high pressure alarm limit.

'I' – 49 hex – ID information. The response is a variable-length string with two sub-strings, separated by a semicolon. The first substring is the name of the firmware in the NETCOM. The second is the serial number of the unit.

'Q' – 51 hex – Enhanced quick status (similar to the '2' command). The return is a four-character string. The first character is the same as is returned by the '2' command. The next three characters are the pressure in hundredths of a PSI (there is no metric equivalent for this command).

Meaning of the string for the E and M commands:

Chars 0,1,2: the current pressure, in hundredths of a PSI or in mbars

Chars 3,4,5,6: current temperature, in degrees F or C. Character 3 is + or -

Chars 7,8,9: duty cycle, in percent.

Char 10: descriptor for “superstate”: only important for a master:

S: Unit is a slave

M: Unit is a master, and system is online

N: Unit is a master, and whole system is in stand-by

D: Unit is a director, and system is online

E: Unit is a director, and whole system is offline

(Note: Director mode is not yet implemented.)

Char 11: descriptor for major state:

N: On line

S: Stand-by

L: A leaky system; not attempting to pump

R: Remote mode: pumps as directed by master

A: Alternating: not used (legacy state)

J: Joint: the master’s state during parallel pumping

(Note: This feature is not yet implemented.)

Char 12: state of the environment (temperature):

N: normal

C: cold

H: hot

Char 13: condition of canister 1:

O: Okay; normal, dry

F: Full; wet

U: Unknown; used for a while after unit is powered up

D: Dead; failed to regenerate and will not be used if avoidable.

Char 14: usage of canister 1:

I: idle (not being used)

U: in use (for pressurization)

R: being regenerated

Char 15: condition of canister 2: as in char 13

Char 16: usage of canister 2: as in char 14

Char 17: 'A' if there is an alarm condition, '-' if not.

#### THE X COMMAND:

The X command is used to “forward” a command through the master ADH NETCOM automatic dehydrator to a slave unit when they are connected via a serial connection. The X command will not function for master and slave sets connected via Ethernet where the master and slave can each be directly communicated with.

There are two forms of the X command:

Form One – One data byte, the command to forward. The address is understood to mean the slave.

Form Two – Two data bytes: the first is an address, the second the command to forward. The address byte must be either '1', meaning forward to the slave, or '0', meaning the recipient should do it himself.

If the command is to be forwarded and the unit is not a master, the X command will be rejected. The X command will be accepted if it is possible to forward it to a slave, even if we know that the slave will reject it. This is to allow the possibility that in the future the slave will have features that the master does not have.

There are certain commands that are never forwarded. At the moment, this includes the '7' and '8' commands, the 'J' and '[' and ']' commands (all of which can cause an actual effect on the slave), as well as the X command itself.

The response to the X command is as follows:

First data byte: repeat of the address character ('0' or '1')

Second data byte: repeat of the command being forwarded

Third data byte: status of the command

After this, comes any returned data.

The status bytes are:

Y: Slave returned an ACK

N: Command returned a NAK

T: Command timed out: no return within 1/2 second

B: System too busy to send command.

#### Example S-A Communication Session

Suppose we wish to communicate with an ADH-3COM that has no address jumpers set, making the user-selected address 0. Then we add 30 hex to this number (remember, 30 hex gets added to every address). This makes for a final address of 30 hex for this ADH-3COM. Now, suppose we wish to retrieve the unit's status. The command line we use is 31. Following is the string of bytes that must be sent:

02, 30, 31, 03, 00

The bytes, in order, are STX, ADDRESS, COMMAND, ETX, CHECKSUM.

A typical response may be:

06, 30, 31, 45, 30, 31, 33, 2b, 30, 36, 30, 55, 52, 30, 31, 30, 30, 31, 35, 2d, 2d,  
2d, 2d, 2d, 2b, 2d, 2d, 2d, 2d, 2d, 2d, 2d, 2d, 2d, 57, 20, 03, 30



This message decodes as follows:

06, 30, 31 = STX, ADDRESS, COMMAND

45, 30, 31, 33 = E013 = English, 0.13 psig. The decimal point is assumed and its location is determined by pressure and display options.

2b, 30, 36, 30 = +060 = +60°F

55, 52 = UR = Absorption unit #1 in use, absorption unit #2 regenerating.

30, 31, 35 = 015 = 0.015cfm flow rate

2d, 2d, 2d, 2d, 2d, 2b, 2d, 2d, 2d, 2d, 2d, 2d, 2d, 57, 20 = --W = Indicates that Warning 6 (low line voltage) has been issued and no alarms are present.

03, 30 = ETX, CHECKSUM

Note: The 13 data fields following the flow rate field correspond to the alarms and warnings shown in Table 7 on page 38 of this manual.

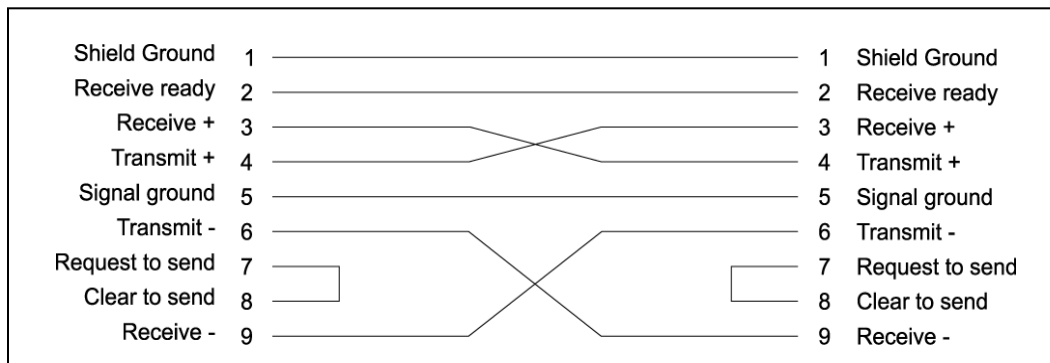
## APPENDIX C – MASTER CONFIGURATION

### PURPOSE

An ADH NETCOM automatic air dehydrator can be configured as a master dehydrator to control another ADH NETCOM, an ADH-3COM, or an ADH-2A COM automatic air dehydrator. The connected master/slave dehydrator pair can be connected to the same pressurization system to provide redundancy and increase the system reliability.

### DESCRIPTION

The two air dehydrators in the master/slave configuration communicate with each other over an Ethernet network or directly connected via the serial RS-232 or RS-422/485 ports. If paired with an ADH-2A COM or ADH-3COM, the ADH NETCOM must connect via an RS-422/485 connection. The interface cable wiring connection is shown in Figure 1. The master and slave units must have the same baud rate set for serial RS-232 and RS-422/485 connections. It is recommended to use 9600 baud in the master/slave configuration.



**Figure 1. INTERFACE CABLE WIRING CONNECTION.**

Under normal conditions, the master and slave unit will alternate control of air dehydration in the waveguide system, each being on line for 50 hours. When one unit is in control, the other will be in a stand-by mode.

Three conditions will cause an ADH NETCOM to relinquish control to the connected dehydrator. The three conditions are:

- Unit unable to perform air dehydration;
- Unit unable to attain desired pressure; and
- Master/slave communication failure.

Condition 1 would occur if both absorption units in the air dehydrator fail or an absorption unit has failed and the other needs to be regenerated. Once a unit has relinquished control for this condition, it will not get it back unless the condition goes away.

Condition 2 would exist if a unit runs for one hour without attaining the desired pressure. The unit declares itself leaky. This is a permanent condition, unless the other unit also declares itself leaky.

Condition 3 would occur either if the master does not receive a response from the slave in 5 minutes, or if the slave does not receive a message from the master in 15 minutes.

## ORDERING INFORMATION

Order Number	Description
23437	ADH NETCOM Automatic Air Dehydrator, AC
23242	ADH NETCOM Automatic Air Dehydrator, DC
23483	ADH NETCOM Automatic Air Dehydrator, AC, NEMA
23589	ADH NETCOM Automatic Air Dehydrator, DC, NEMA
23740	ADH NETCOM NEMA Automatic Dehydrator, 100-240 VAC (w/ Mil-Spec Connectors)
23742	ADH NETCOM NEMA Automatic Dehydrator, ±20-75 VDC (w/ Mil-Spec Connectors)
23526	ADH NETCOM Installation & Operation Manual (this document)
23229	ADH NETCOM with Redundant DC Power Installation Sheet
23481	ADH NETCOM NEMA with AC Power Installation Sheet
23617	ADH NETCOM with AC Power Installation Sheet

Accessories	Description
23739	ADH NETCOM NEMA Mil-Spec Connector Accessory Kit (for 23483 & 23589)

## QUESTIONS AND COMMENTS

For technical help, questions, or comments concerning this product or any of Environmental Technology, Inc., products, contact the Customer Service Department between 8:00 a.m. and 5:00 p.m. Eastern Time at:

Voice: (800) 234-4239 (USA and Canada) or (574) 233-1202 (elsewhere)  
 Fax: (888) 234-4238 (USA and Canada) or (574) 233-2152 (elsewhere)  
 E-mail: [info@networketi.com](mailto:info@networketi.com)

## DISCLAIMER

Environmental Technology, Inc. makes no representations or warranties, either expressed or implied, with respect to the contents of this publication or the products that it describes, **and specifically disclaims any implied warranties of merchantability or fitness for any particular purpose.** Environmental Technology, Inc. reserves the right to revise this publication and to make changes and improvements to the products described in this publication without the obligation of Environmental Technology, Inc. to notify any person or organization of such revisions, changes or improvements.

No part of this manual may be reproduced or translated in any form or by any means, electronic or mechanical including photocopying and recording, for any purpose without the express written consent of Environmental Technology, Inc.

The ETI logo, We Manage Heat, ASM, and ADH are registered trademarks of Environmental Technology, Inc. NETCOM and Smart Manifold are trademarks of Environmental Technology, Inc.

Copyright © 2010 Environmental Technology, Inc. All rights reserved.