



ADH[®]-3COM

Procedure for replacing obsolete pump with maintenance free, extended life compressor

Part Number 23032

Document Part Number 23034

DESCRIPTION

A maintenance-free, long life Hargraves compressor has been instituted as an across the board replacement for the obsolete KNF pump in ADH-3COM Dehydrators. The advantages of the new compressor are:

- Brushless motor for long life and zero maintenance.
- Hargraves' proprietary diaphragm material for longer life.
- Higher airflow at pressures above 2 PSI, similar airflow below 2 PSI.
- Smaller, lighter unit.
- More efficient design requires less power to operate.

This procedure documents the steps required to perform a field upgrade from the old pump to the new brushless unit.

PACKING LIST

23032	Hargraves Compressor Pump, small (Qty. 1)
12522	Hex nut (Qty. 4)
10378	Washer (Qty. 4)
16979	Spacer (Qty. 4)
17082	Cable Tie (Qty. 1)
17369	Tie Wrap Mount (Qty. 1)
23034	ADH-3COM Pump Replacement Manual

Environmental Technology, Inc.
1850 N Sheridan Street • South Bend, IN 46628
(574) 233-1202 • Fax (574) 233-2152
Toll Free (800) 234-4239 • Fax (888) 234-4238
www.networketi.com • helpdesk@networketi.com

Step 1: Turn off unit and remove plug.

Step 2: Remove top cover.

For rack mount units, remove 12 screws.
For wall mount units, remove 10 screws.

Step 3: Unscrew and remove the red and black wires. If wires cannot easily be removed from ferrite core, cut cable tie and open core to remove wires. Retain ferrite core for re-installation later in this procedure.

Step 4: Disconnect tubing from solenoid barbed fitting.

Step 5: Disconnect ground wire.

Step 6: Remove 4 mounting screws from under side of unit (secure pump with other hand). Keep 4 mounting screws and lock washers for use to install new pump.

Step 7: Install 4 mounting screws and spacers in the locations shown in preparation for new pump. Install ferrite core in new position using tie wrap mount.

Step 8: Position Hargraves compressor mounting bracket over spacers and secure with 4 nuts.

Step 9: Route the red and black wires through the ferrite core, secure core with cable tie, then re-install the core in a new location as shown using the tie wrap mount.

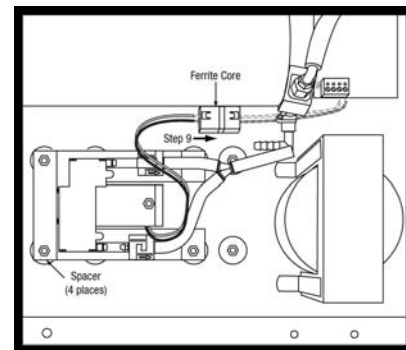
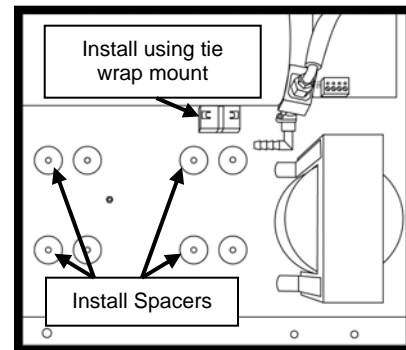
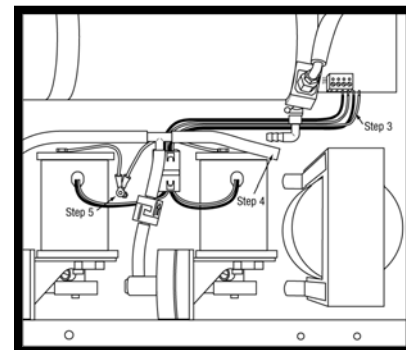
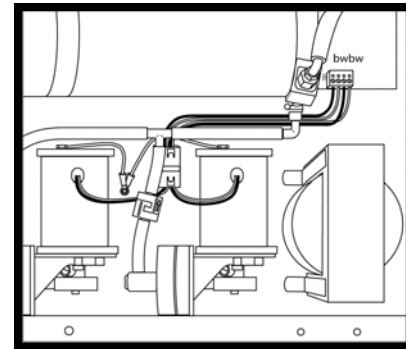



The new DC brushless pump is polarized. Failing to wire as shown will damage the pump motor and can cause additional damage to the dehydrator.

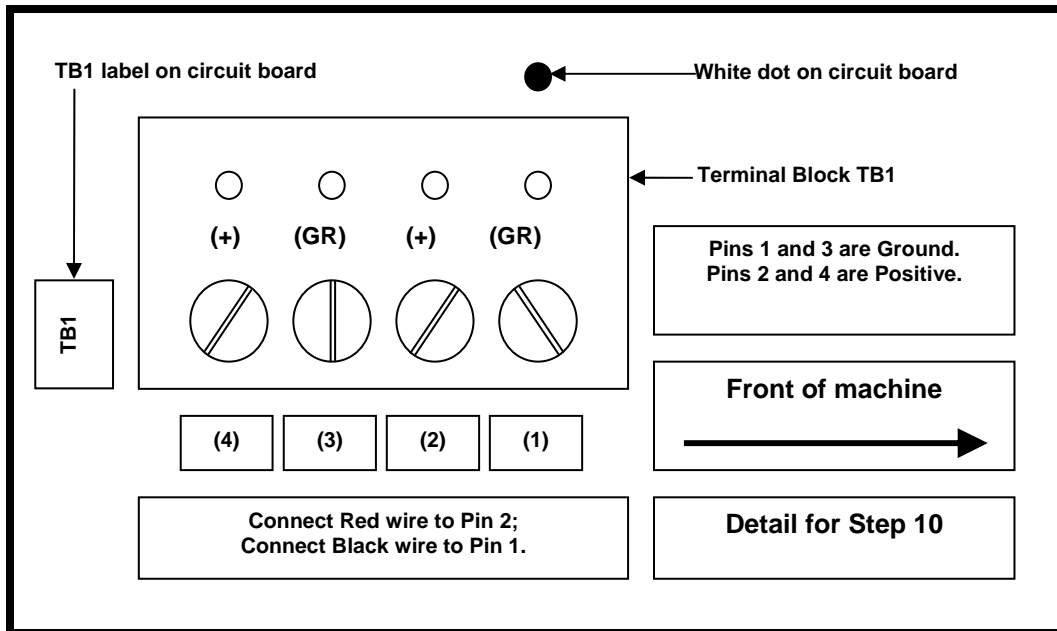

Step 10: Insert red wire into Pin 2 of terminal block TB1. Insert black wire into Pin 1 of terminal block TB1.

Step 11: Connect air line tubing to solenoid barbed fitting.

Step 12: Reinstall cover.

Step 13: Reconnect power cord and turn on unit.

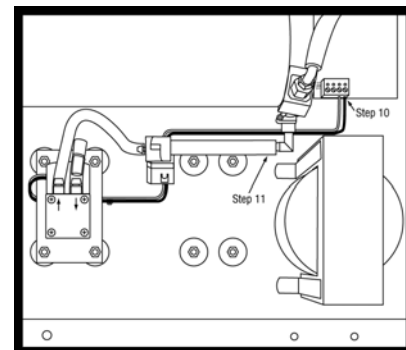



QUESTIONS AND COMMENTS

For technical help, questions, or comments concerning this or any Environmental Technology, Inc. product, contact the Customer Service Department between 8:00 a.m. and 5:00 p.m. EST.

Voice: (800) 234-4239 (USA and Canada) or (574) 233-1202 (elsewhere)
Fax: (888) 234-4238 (USA and Canada) or (574) 233-2152 (elsewhere)
E-mail: helpdesk@networketi.com

DISCLAIMER

Environmental Technology, Inc. makes no representations or warranties, either expressed or implied, with respect to the contents of this publication or the products that it describes, and specifically disclaims any implied warranties of merchantability or fitness for any particular purpose. Environmental Technology, Inc. reserves the right to revise this publication, and to make changes and improvements to the products described in this publication, without the obligation of Environmental Technology, Inc. to notify any person or organization of such revisions, changes or improvements.

The ETI logo, We Manage Heat and ADH are registered trademarks of Environmental Technology, Inc. Copyright © 2010 Environmental Technology, Inc. All rights reserved.