

Packing List

Qty	ETI P/N	Description
1	23242	ADH NETCOM Automatic Dehydrator, Redundant DC Power Supply
1	23526	ADH NETCOM Instruction Manual
1	23229	ADH NETCOM Installation Sheet (this document)
1	18198	1/8" NPT to 1/4" Barbed Brass Fitting
1	23428	1/8" NPT to 3/8" Barbed Brass Fitting
1	14513	1/8" NPT to 1/4" Barbed Elbow Brass Fitting
4	23245	Mounting Bracket
8	11040	Rack-mounting screw (#8-32)
8	10641	#8 Split Washer

Connections

1. Connect feed hose to 1/8" NPT outlet using 1/4" or 3/8" barbed fitting supplied.
 2. Connect required data and alarm relay ports. RS-422 and RS-232 ports may require configuration changes via the web interface. See Instruction Manual for more information.
- Note: Unit does not have power switch. When power is applied to either power input, the system will start.**
3. Connect DC power supply. System can be connected to two independent supplies providing $\pm 20-75$ VDC. Attach to Supply 1 (negative and positive) and Supply 2 (negative and positive) as shown on the panel. Attach ground to either the ground lug or the ground terminal on the terminal block.

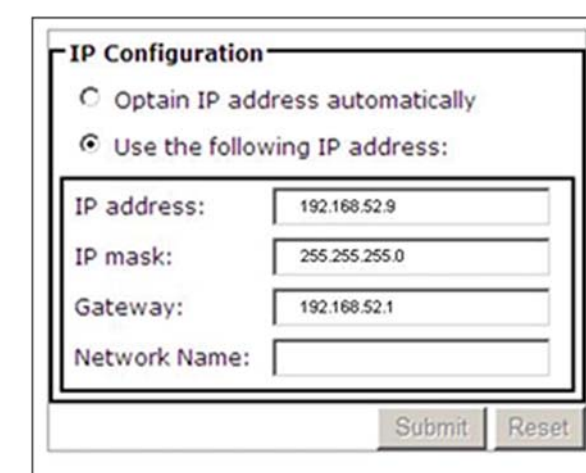

IP Configuration

Obtain IP address automatically

Use the following IP address:

IP address: 192.168.52.9

IP mask: 255.255.255.0

Gateway: 192.168.52.1

Network Name:

Submit Reset

Communicating With the Dehydrator

Note: Your Information Technology Department is the best source of information if you encounter problems or difficulties in connecting to or communicating with the dehydrator.

1. Temporarily assign computer an IP address in the 192.168.52.0 network range, typically 192.168.52.1, with the subnet 255.255.255.0
2. Connect the dehydrator to your computer either directly or through a network. For direct connections a cross-over cable or switch may be required for connecting to an older computer; an Ethernet patch cable will work in most other cases.
3. Open a web browser and connect to web interface at HTTP: //192.168.52.9

Configuring IP Address

1. Go to Configuration page
2. If using a fixed IP address, select "Use the following IP address:" Then set the IP address, mask and gateway.
3. If using DHCP, select "Obtain IP address automatically."
4. Click Submit. You should see a message that the dehydrator is rebooting.

Note: After changing the IP address of you dehydrator to a network other than the default 192.168.52.0 you will not be able to access the dehydrator from the configuring computer unless that computer is reconfigured for the newly assigned network address.

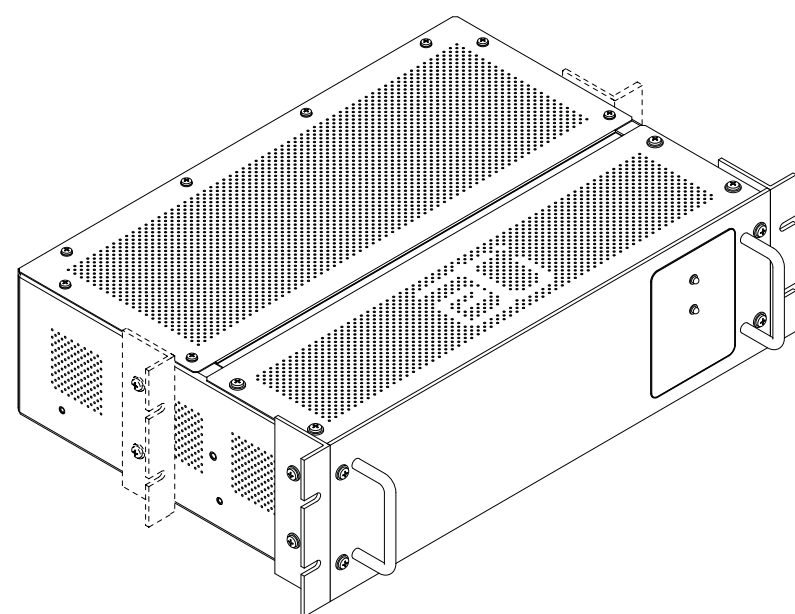
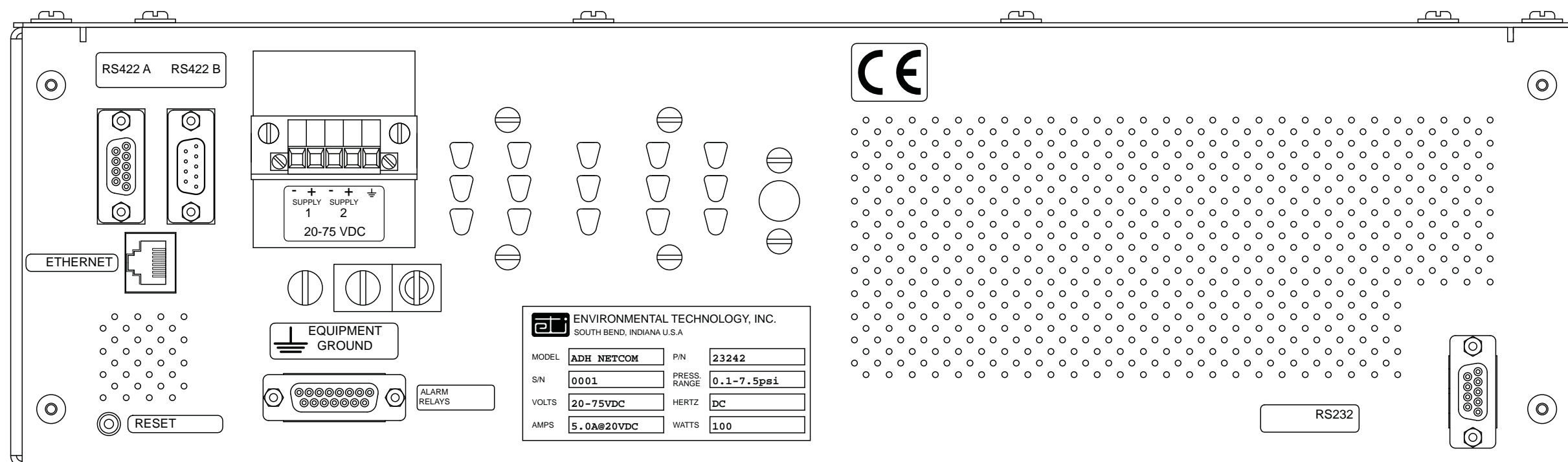

Rack Mounting

The dehydrator is equipped with positions for either flush-mounting (for dual-post racks and enclosures) or center-mounting (for single-post racks).

If using mounting rails (not supplied), do not install mounting brackets.

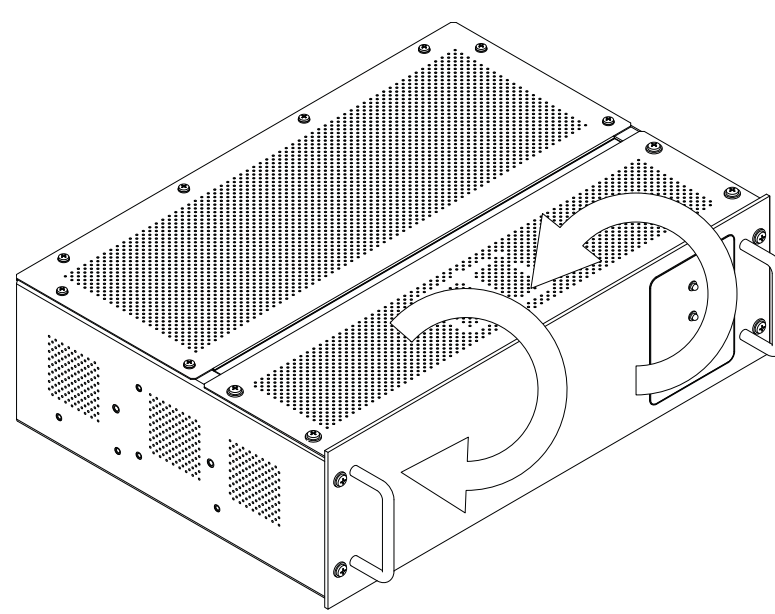

Wall Mounting Configuration

To configure the dehydrator for wall mount installation, remove the front panel and the portion of the vented cover with the ETI logo. Reinstall the front panel so that it will be in the new front position once the dehydrator is oriented for wall mounting. Reinstall the small vented panel so that it will be in the new bottom position.

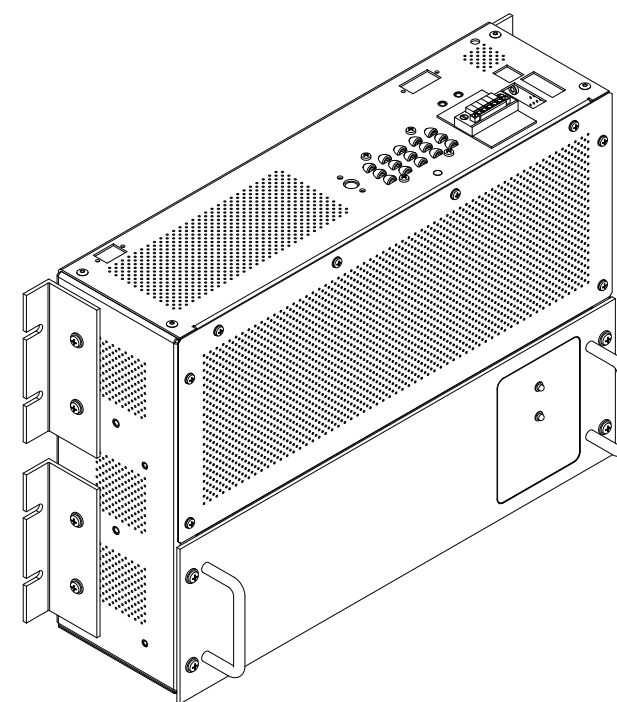

Wall Mounting

Ensure the mounting surface and hardware are suitable to support a static load of approximately four times the weight of the unit, or 64 pounds (29 kg). Use four appropriate 5/16" mounting hardware to fasten the unit and ensure stable mounting. The dehydrator is equipped with four brackets for wall mounting.

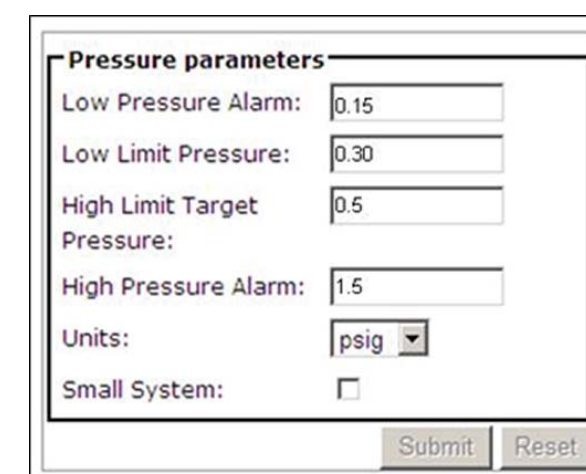

Pressure parameters

Low Pressure Alarm: 0.15

Low Limit Pressure: 0.30

High Limit Target Pressure: 0.5

High Pressure Alarm: 1.5

Units: psig

Small System:

Submit Reset

Configuring Pressure

1. Using a web browser, connect to the dehydrator. Go to the Configuration page
2. Using the Units pull-down select English (PSI) or SI (mbar).
3. To change the operational pressure setting enter the following:
 - Low Alarm - The pressure at which Low Pressure will cause an alarm condition.
 - Low Limit - The low set point at which the unit will start pumping.
 - High Limit - The high set point at which the unit will stop pumping.
 - High Alarm - The pressure at which High Pressure will cause an alarm condition.
4. Click submit.

Questions & Comments

For technical help, questions or comments concerning this product or any Environmental Technology, Inc. product contact:

Customer Service 8:00 a.m. - 5:00 p.m. EST.
Voice: (800) 234-4239 USA & Canada or
(574) 233-1202 elsewhere
Fax: (888) 234-4238 USA & Canada or
(574) 233-2152 elsewhere
Email: info@networketi.com
Web: <http://www.networketi.com>

DISCLAIMER

Environmental Technology, Inc. makes no representations or warranties, either expressed or implied, with respect to the contents of this publication or the products that it describes, and specifically disclaims any implied warranties of merchantability or fitness for any particular purpose. Environmental Technology, Inc. reserves the right to revise this publication, and to make changes and improvements to the products described in this publication, without the obligation of Environmental Technology, Inc. to notify any person or organization of such revisions, changes or improvements.

The ETI logo, We Manage Heat and ADH are registered trademarks of Environmental Technology, Inc. Copyright © 2009 Environmental Technology, Inc. All rights reserved.