



BENEFITS

- Automatic snow/ice melting control
- Minimum energy costs

FEATURES

- Multiple sensor capability
- Remote control option
- Controls up to 10 satellite contactors
- Timed heater cycle capability
- U-L Listed, CSA Certified
- Single and three-phase power control
- Available at 208, 240, 277, 480 and 600 volts
- Contactor rating of 50 amps per pole
- Simple installation

DESCRIPTION

The patented APS-4 provides effective, economical automatic control of snow melting systems including those for gutter and down spouts. The ability to use multiple sensors ensures optimum control of large systems.

Supply voltage options include 240 volt single phase or 208, 277, 480 and 600 volts 3-phase, with a contactor rating of 50 amps per pole. The integral 30 mA ground fault circuit interrupter with a test/reset facility ensures safety along with NEC and local code compliance. The APS-4 operates up to ten SC-40 Satellite Contactors for larger loads.

The adjustable 10 hour hold-on timer keeps heaters operating after snow stops to ensure complete melting. A cycle switch can be used to operate heaters for the hold-on timer setting. This useful feature melts tracked or blowing snow or ice. LED indicators permit monitoring snow melting system operation.

The optional patented RCU-1 Remote Control provides monitoring and control of the snow melting system at a convenient location.

For installation simplicity and low cost, sensors, the RCU-1, and satellite contactor control wiring is NEC Class 2. The APS-4's non-metallic enclosure is rated for protected NEMA 3R locations in the temperature range of -40° to 160°F (-40° to 60°C).

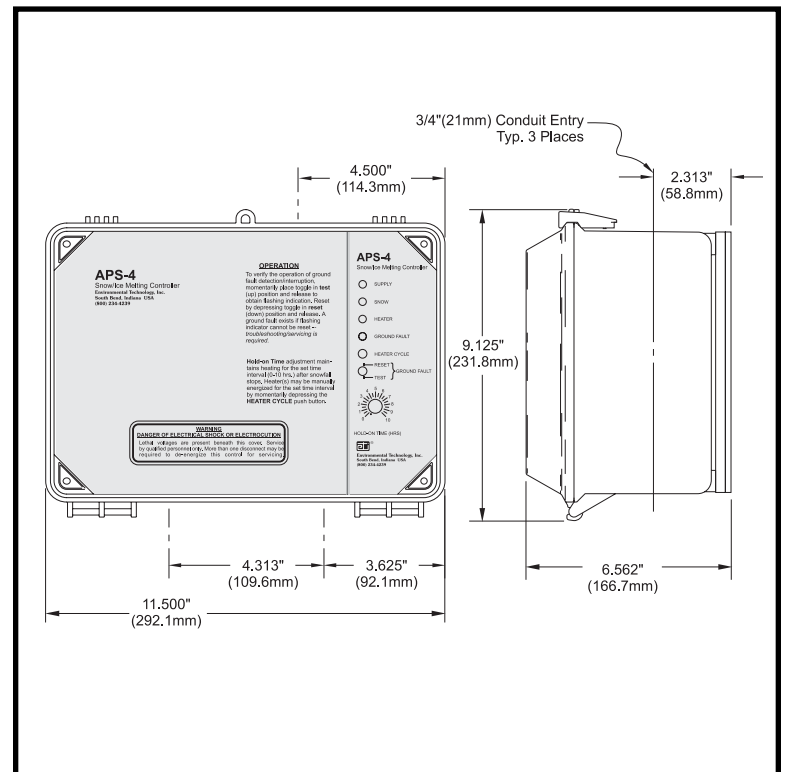

INSTALLATION

Comply with all applicable electrical and building codes and regulations. The APS-4's nonmetallic enclosure is furnished with three 3/4" (21mm) conduit openings; if installed in a hostile environment, ensure that all conduit terminations are watertight.

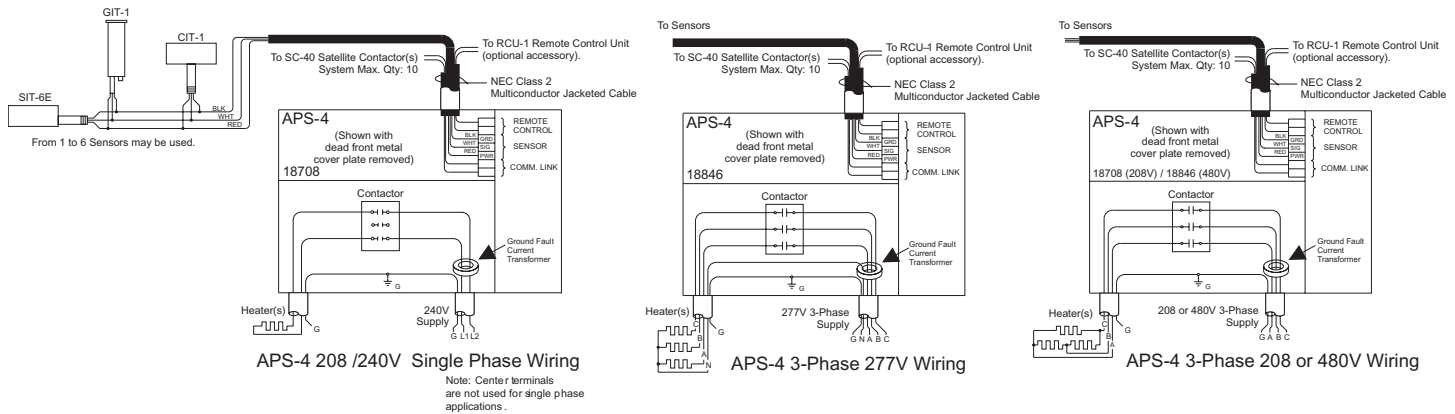

Typical Wiring Diagrams

Remote Control and Satellite Contactor Cable(s) (by Purchaser): 2/c #18 AWG; max. length: 2000' (609.6 m).
 Sensor loop cable (by purchaser): max. length from most distant sensor, 2000' (609.6 m); 3/c #18 AWG for lengths up to 500' (152.4 m) with one sensor and 250' (76.2m) with two sensors, #12 AWG for greater lengths. Contact customer service for multiple sensor installation.

ORDERING INFORMATION

Order Number	Description
17709	APS-4 Control Panel, 277 VAC, Single Phase
18708	APS-4 Control Panel, 208/240 VAC
18846	APS-4 Control Panel, 277/480 VAC
19608	APS-Control Panel, 600 VAC
17542	RCU-1 Remote Control Unit
10001	CIT-1 Aerial Snow Sensor (optional)*
11351	GIT-1 Gutter Ice Sensor (optional)*
20756	SIT-6E Pavement-mounted Sensor (optional)*

* A system requires at least one sensor

LIMITED WARRANTY

ETI's two year limited warranty covering defects in workmanship and materials applies. Contact Customer Service for complete warranty information.

DISCLAIMER

Environmental Technology, Inc. makes no representations or warranties, either expressed or implied, with respect to the contents of this publication or the products that it describes, and **specifically disclaims any implied warranties of merchantability or fitness for any particular purpose**. Environmental Technology, Inc. reserves the right to revise this publication, and to make changes and improvements to the products described in this publication, without the obligation of Environmental Technology, Inc. to notify any person or organization of such revisions, changes or improvements.



1850 N Sheridan Street, South Bend, IN 46628 (574) 233-1202/Fax (574) 233-2152/Toll Free (800) 234-4239/Toll Free Fax (888) 234-4238
<http://www.networketi.com> / e-mail: helpdesk@networketi.com

The ETI logo, Snow Switch, Floorstat, Tracon, We Provide Managed Heat, We Manage Heat are registered trademarks of Environmental Technology, Inc. 99+, ADH, APS, CIT, EDH, EUR, ES, FMC, FWT, GIT GPT, HSC, LCD, RCD, RCU, RMC and SIT are Environmental Technology, Inc. trade marks. Copyright © 2000 Environmental Technology, Inc. All rights reserved.

4/2005 18631